



# LogiCool™ OnRak IT Cooling



## Technical, Installation, Operational and Maintenance Manual



ISO 14001  
EMS52085



ISO 9001  
FM00542

## About Airedale Products & Customer Services

**Warranty, Commissioning & Maintenance** As standard, Airedale guarantees all non consumable **parts only** for a period of **18 months**, variations tailored to suit product and application are also available; please contact Airedale for full terms and details.

To further protect your investment in Airedale products, Airedale can provide full commissioning services, comprehensive maintenance packages and service cover 24 hours a day, 365 days a year (UK mainland). For a free quotation contact Airedale or your local Sales Engineer.

All Airedale products are designed in accordance with EU Directives regarding prevention of build up of water, associated with the risk of contaminants such as Legionella.

For effective prevention of such risk it is necessary that the equipment is maintained in accordance with Airedale recommendations.

### CAUTION



Warranty cover is not a substitute for maintenance. Warranty cover is conditional to maintenance being carried out in accordance with the recommendations provided during the warranty period. Failure to have the maintenance procedures carried out will invalidate the warranty and any liabilities by Airedale International Air Conditioning Ltd.

### Spares

A spares list for 1, 3 and 5 years will be supplied with every unit and is also available from our Spares department on request.

### Training

As well as our comprehensive range of products, Airedale offers a modular range of Refrigeration and Air Conditioning Training courses, for further information please contact Airedale.

### Customer Services

For further assistance, please e-mail: [enquiries@airedale.com](mailto:enquiries@airedale.com) or telephone:

UK Sales Enquiries	+ 44 (0) 113 238 7789	<a href="mailto:enquiries@airedale.com">enquiries@airedale.com</a>
International Enquiries	+ 44 (0) 113 239 1000	<a href="mailto:enquiries@airedale.com">enquiries@airedale.com</a>
Spares Hot Line	+ 44 (0) 113 238 7878	<a href="mailto:spares@airedale.com">spares@airedale.com</a>
Airedale Service	+ 44 (0) 113 239 1000	<a href="mailto:service@airedale.com">service@airedale.com</a>
Technical Support	+ 44 (0) 113 239 1000	<a href="mailto:tech.support@airedale.com">tech.support@airedale.com</a>
Training Enquiries	+ 44 (0) 113 239 1000	<a href="mailto:marketing@airedale.com">marketing@airedale.com</a>

For information, visit us at our Web Site: [www.airedale.com](http://www.airedale.com)

### Legal Notices

AIAC Ltd endeavours to ensure that the information in this document is correct and fairly stated, but none of the statements are to be relied upon as a statement or representation of fact. AIAC Ltd does not accept liability for any error or omission, or for any reliance placed on the information contained in this document.

The development of Airedale products and services is continuous and the information in this document may not be up to date. It is important to check the current position with AIAC Ltd at the address stated. This document is not part of a contract or licence unless expressly agreed.

No part of this document may be reproduced or transmitted in any form or by any means, electronic or mechanical, including photocopying, recording, or information storage and retrieval systems, for any purpose other than the purchaser's personal use, without the express written permission of AIAC Ltd.

Cover image for illustration only

© 2014 Airedale International Air Conditioning Limited. All rights reserved. Printed in the UK.

## Warranty

### Warranty

All AIAC products or parts (non consumable) supplied for installation within the UK mainland and commissioned by an AIAC engineer, carry a full Parts & Labour warranty for a period of 12 months from the date of commissioning or 18 months from the date of despatch, whichever is the sooner.

Parts or Equipment supplied by AIAC for installation within the UK or for Export that are properly commissioned in accordance with AIAC standards and specification, not commissioned by an AIAC engineer; carry a 12 month warranty on non consumable Parts only from the date of commissioning or 18 months from the date of despatch, whichever is the sooner.

Parts or equipment installed or commissioned not to acceptable AIAC standards or specification invalidate all warranty.

### Warranty is only valid in the event that

In the period between delivery and commissioning the equipment: is properly protected & serviced as per the AIAC installation & maintenance manual provided where applicable the glycol content is maintained to the correct level.

In the event of a problem being reported and once warranty is confirmed as valid under the given installation and operating conditions, the Company will provide the appropriate warranty coverage (as detailed above) attributable to the rectification of any affected Airedale equipment supplied (excluding costs for any specialist access or lifting equipment that must be ordered by the customer).

Any spare part supplied by Airedale under warranty shall be warranted for the unexpired period of the warranty or 3 months from delivery, whichever period is the longer.

To be read in conjunction with the Airedale Conditions of Sale - Warranty and Warranty Procedure, available upon request.

### Procedure

When a component part fails, a replacement part should be obtained through our Spares department. If the part is considered to be under warranty, the following details are required to process this requirement.

Full description of part required, including Airedale's part number, if known  
The original equipment serial number  
An appropriate purchase order number

A spares order will be raised under our warranty system and the replacement part will be despatched, usually within 24 hours should they be in stock.

When replaced, the faulty part must be returned to Airedale with a suitably completed and securely attached "Faulty Component Return" (FCR) tag. FCR tags are available from Airedale and supplied with each Warranty order.

On receipt of the faulty part, suitably tagged, Airedale will pass to its Warranty department, where it will be fully inspected and tested in order to identify the reason for failure, identifying at the same time whether warranty is justified or not.

On completion of the investigation of the returned part, a full "Report on Goods Returned" will be issued. On occasion the release of this complete report may be delayed as component manufacturers become involved in the investigation.

When warranty is allowed, a credit against the Warranty invoice will be raised. Should warranty be refused the Warranty invoice becomes payable on normal terms.

### Exclusions

Warranty may be refused for the following reasons:

- Misapplication of product or component
- Incorrect site installation
- Incomplete commissioning documentation
- Inadequate site installation
- Inadequate site maintenance
- Damage caused by mishandling
- Replaced part being returned damaged without explanation
- Unnecessary delays incurred in return of defective component

### Returns analysis

All faulty components returned under warranty are analysed on a monthly basis as a means of verifying component and product reliability as well as supplier performance. It is important that all component failures are reported correctly.

## Health and Safety

### IMPORTANT

The information contained in this manual is critical to the correct operation and maintenance of the unit and should be read by all persons responsible for the installation, commissioning and maintenance of this Airedale unit.

The equipment has been designed and manufactured to meet international safety standards but, like any mechanical/electrical equipment, care must be taken if you are to obtain the best results.

### CAUTION



Installation, service and maintenance of Airedale equipment should only be carried out by technically trained competent personnel.

### CAUTION



When working with any air conditioning units ensure that the electrical isolator is switched off prior to servicing or repair work and that there is no power to any part of the equipment.

Also ensure that there are no other power feeds to the unit such as fire alarm circuits, BMS circuits etc.

Electrical installation commissioning and maintenance work on this equipment should be undertaken by competent and trained personnel in accordance with local relevant standards and codes of practice.

### Personal Protective Equipment

Airedale recommends that Personal Protective Equipment is used whilst installing, maintaining and commissioning equipment.

### Electrical Bonding

It is important that the components attached to the server rack are electrically bonded to earth correctly.

It is recommended that a mechanical earth strap is used at the following locations

- Doors
- Mating Flange
- LogiCool OnRak
- LogiCool OnRak Chilled Water Coil
- Dual Power Supplies

## CONTENTS

<b>About Airedale Products &amp; Customer Services</b> .....	<b>2</b>
<b>Warranty</b> .....	<b>3</b>
<b>Health and Safety</b> .....	<b>4</b>
Personal Protective Equipment .....	4
Electrical Bonding .....	4
<b>Specifier's Guide Indoor Unit</b> .....	<b>6</b>
Nomenclature .....	6
Introduction .....	6
Standard Features .....	7
Optional Features .....	9
<b>Technical Data</b> .....	<b>12</b>
Design Parameters .....	12
Cooling Performance LOR 6042U-C028-0 (N+1 configuration, Fans at 75%) .....	13
Cooling Performance LOR 6042U-C033-0 (N Configuration, Fans at 100%) .....	14
Cooling Performance LOR 8042U-C032-0 (N+1 configuration, Fans at 75%) .....	15
Cooling Performance LOR 8042U-C038-0 (N Configuration, Fans at 100%) .....	16
Ethylene Glycol Correction Factors .....	17
Mechanical Data .....	18
Electrical Data .....	18
Waterside Pressure Drop .....	18
Dimensional Data .....	20
Component Masses .....	20
Sound Measurement Method .....	21
Noise Data .....	21
Pipework Schematics .....	22
<b>Installation</b> .....	<b>24</b>
Positioning .....	24
Data Rack Feet .....	25
Rack Support Wheel .....	26
Wheel Adjustment .....	26
Door Latch Mechanism .....	27
Floor Cut Outs .....	28
Water Connections .....	29
Flexible Water Connection .....	30
Pipework Sweep .....	30
Compression Fittings .....	31
Chilled Water Valve (2+3 Way) .....	32
Solenoid Valve .....	34
Customer Terminal Box .....	35
Dual Power Supply .....	35
Rack Mounted Temperature / Humidity Sensor .....	38
Rack Pressure Management .....	39
Rack Sealing .....	40
Interconnecting Wiring .....	41
Automatic Fan Disconnect .....	42
<b>Controls</b> .....	<b>43</b>
Addressing the Display Keypad .....	43
Extra Functions Buttons .....	45
Navigation .....	45
Enabling the Unit .....	46
Dew Point Control .....	47
Modulated Cooling .....	47
Temperature Sensor Locations .....	48
<b>Modes of Operation</b> .....	<b>49</b>
Temperature Neutral Mode .....	49
Load Neutral Mode .....	50
Rack Pressure Management .....	51
<b>Commissioning Procedure</b> .....	<b>52</b>
General .....	52
<b>Maintenance</b> .....	<b>54</b>
<b>Operational Maintenance checks</b> .....	<b>55</b>
Owners Responsibility .....	55
Maintenance Schedule .....	55
<b>Troubleshooting</b> .....	<b>56</b>

## Specifier's Guide Indoor Unit

### Nomenclature

Example: LOR 60 42U - C 033 - 0

LOR	LogiCool OnRak
60 80	Case width in centimetres
42U	Unit height in U
-	Separator
C	Chilled water cooling
028 033	Nominal cooling capacity in kW
-	Separator
0	230V / 1Ph / 50Hz / 60Hz

### Introduction

The OnRak is a compact rear door heat exchanger designed to manage discharge temperatures from a server rack into the aisle space.

In dealing with the heat load closer to the source, the OnRak is highly efficient in floor Space and power usage. Elevated air temperature combined with increased water temperature allows the OnRak to take advantage of free cooling applications.

Part of the LogiCool range of IT cooling solutions, the OnRak offers an expandable cooling system that can be supplied with an industry standard data rack (42 - 48U) or a mating frame to fit a customer-specific rack.

The OnRak is available in both 600mm and 800mm widths.

The slim configuration of the OnRak ensures minimal impact into the aisle.

The OnRak air volumes are based on an N (All four fans operating 100%) and N+1 (fans operating at a reduced speed to 75%). This configuration greatly increases the energy efficiency ratio (EER) of the equipment.

### CE Directive

**CE** Airedale certify that the equipment detailed in this manual conforms with the following EC Directives:

Electromagnetic Compatibility Directive (EMC)	<b>2004/108/EC</b>
Low Voltage Directive (LVD)	<b>2006/95/EC</b>
Machinery Directive (MD)	<b>89/392/EEC in the version</b>
	<b>2006/42/EC</b>
Pressure Equipment Directive (PED)	<b>97/23/EC</b>

To comply with these directives appropriate national & harmonised standards have been applied. These are listed on the Declaration of Conformity, supplied with each product.

Maximum and Minimum Operation Temperature (TS) and Pressure (PS)	
Operating Temperature (TS),	TS = Min -20°C to Max 120°C *
Maximum Operating Pressure (PS)	PS = High Side 26 Barg

\*Based upon the maximum machine running temperatures.

## Standard Features

The OnRak unit comes with a series of standard features.

Standard Features	LOR 6042U-C0 28-0	LOR 6042U-C0 33-0	LOR 8042U-C032-0	LOR 8042U-C038-0
EC axial fans	•	•	•	•
EC fan node	•	•	•	•
0-10V 2 or 3 way chilled water valve	•	•	•	•
Advanced Airetronix controls	•	•	•	•
Water temperature sensor	•	•	•	•
Tri coloured LED (Alarm status) for easy fault detection	•	•	•	•
Rack mounted temperature / humidity sensor	•	•	•	•
Leak detection	•	•	•	•
Bleed and drain valves	•	•	•	•

•Features available

### Construction

The cabinet shall be manufactured with galvanised sheet steel to provide a smooth aesthetically pleasing finish. The galvanised sheet steel panels shall be coated with an epoxy baked powder paint to provide a durable finish.

Standard unit colour shall be Black Grey to RAL 7021.

### Fan & Motor Assembly

300mm diameter axial fans with EC motors mounted in bell mouth housing shall be provided to ensure optimum efficiency.

The fan section shall be designed as a hot swap assembly which can be changed quickly minimising downtime during replacement or maintenance.

### Compact Cooling Coil

3/8" plain tube cooling coil with 1.8mm fin pitch and hydrophilic fins

### 0-10 Volts DC Chilled Water 3 Way Valve

A 0-10 VDC chilled water 3 way regulating valve shall be fitted. This shall be used to govern the chilled water going to the coil when there is a demand for cooling.

or

### 0-10 Volts DC Chilled Water 2 Way Valve

A 0-10 VDC chilled water 2 way regulating valve shall be fitted. This shall be used to govern the chilled water going to the coil when there is a demand for cooling.

### Bleed and Drain Valves

Valves shall be factory fitted to easily bleed the system of any air and drain water for maintenance.

### Airetronix Controls

Advanced Airetronix controls strategy with integrated system control, free cooling mode, dew point management, and fan and alarm management shall be provided.

### Water Temperature Sensor

A water temperature sensor shall be fitted to the water inlet pipework.

### Tri colour LED for Easy Fault Detection

LED indication for alarm status shall be incorporated in the front face of the OnRak unit (signals Healthy, Non Critical and Critical Alarm respectively) Green, Yellow and Red.

**Rack Mounted Temperature/ Humidity Sensor**

Rack mounted temperature and Humidity sensor shall be supplied as standard. This shall be supplied loose for onsite fitment in a customer rack.

**Leak Detection**

Leak detection for the water system, able to report alarm status to the BMS system shall be provided. The unit shall then be shut down before any damage occurs. The leak detection tape shall be fitted within the drip tray of the coil.

**Bypass Regulating Valve**

A bypass regulating valve shall be fitted in the bypass leg of the system to enable constant flow when there is no cooling demand. This simulates the coil pressure drop ensuring that the water flow rate does not change irrespective of amount of flow through the chilled water coil.

This enables flow through each cooling module without the need for a Cooling Distribution unit (CDU).

**EC Fan Nodes**

The fan nodes enable independent control. The fan can be interrogated by the controller giving information such as temperature, fan speed, currents and power consumption.

If during a controller failure the fans resume operation at the last setpoint. This ensures downtime is reduced.



## Optional Features

The OnRak unit comes with a series of optional features.

Optional Features	LOR 6042U-C0 28-0	LOR 6042U-C0 33-0	LOR 8042U-C032-0	LOR 8042U-C038-0
Various display options	•	•	•	•
Modbus / Carel BMS connection	•	•	•	•
Lon BMS connection	•	•	•	•
pCOWeb	•	•	•	•
BacNet protocol	•	•	•	•
Programming smart key	•	•	•	•
Threaded pipe connections	•	•	•	•
Quick coupling water connections	•	•	•	•
Flexible hoses of alternative lengths	•	•	•	•
Isolating solenoid valves	•	•	•	•
Dual power supply	•	•	•	•
Uninterrupted Power Supply	•	•	•	•
Static Transfer Switch	•	•	•	•
Room mounted temperature / humidity sensor	•	•	•	•
Rack Pressure Management	•	•	•	•

•Features available

### Display Options

1. White backlit 8 x 22 character, semi-graphical LCD Display. Integrated for local monitoring, adjustment of parameters and commissioning.  
or
2. Semi-graphical LCD Display with Audible alarm.  
or
3. Remote Handheld Display (unit fitted with RJ11 Connection port)  
or
4. No Display (RJ11 Connection port only)

### Modbus / Carel BMS Connection

The Airedale controllers shall be able to communicate directly using the Modbus® protocol.

The Modbus® card shall be a small PCB (60mm x 30mm), which can be plugged into the controller to provide it with the following protocol support

- Modbus® - JBus slave
- RTU mode (Remote Terminal Unit) with 8 bit encoding and error handling using 16 bit CRC
- Communication standard connection options of RS485 (multipoint) or RS232 (point-point)
- Maximum Baud Rate of 19200

The data communication shall be asynchronous serial, 8 data bits, 2 stop bits and no parity (in total 11 bits/datum).

The data/parameters from the controller shall be represented within Modbus® registers, each register containing information pertaining to temperatures, pressures, setpoint, status, etc and is available to the site integration company in a spreadsheet format

<b>Lon BMS Connection</b>	<p>The Airedale controllers, using special serial cards, shall be integrated into LonWorks® networks. The RS485 and the FTT10 standards shall be supported by the LonWorks® serial cards.</p> <p>The two types of LonWorks® serial cards shall differ by the type of interface on the LonWorks® network side:-</p> <p>FTT-10A 78 kbs (TP/FT-10) RS485 39 kbs (TP/485-39)</p>
<b>pCOWeb</b>	<p>pCOWeb is a new generation of Airedale supervisory plug-in cards which make communicating with an Airedale unit simply a matter of logging onto the office Intranet or via the web.</p> <p>Based on Ethernet TCP/IP secure technology, pCOWeb shall require no proprietary cabling. It shall have little or no set-up on site and can be pre-programmed with an IP address prior to dispatch from airedale.</p>
<b>BacNet Protocol</b>	<p>The BACnet protocol option shall be supplied either with a pCOWeb (Ethernet) or pCONet (RS485) interface card.</p>
<b>Programming Smart Key</b>	<p>A smart key shall be supplied to offer software back-up of the control strategy. The key shall feature simple plug in operation and allow transfer of software programs from the key to the microprocessor and vice versa. The use of a service laptop shall not be necessary.</p>
<b>Water Pipework Connections</b>	<p>Various water side connections shall be available. 1" BSP (British Standard Pipe) and 1" self seal fittings, with 1" BSP connections.</p>
<b>Flexible Connections</b>	<p>Stainless steel flexible connections shall be supplied with the unit. They shall be supplied either 1.5m or 3m long. Longer lengths can be provided. Please contact Airedale.</p>
<b>Isolating Solenoid Valves</b>	<p>Isolating solenoid valves shall be fitted to the inlet and outlet connections. This shall control the water flow to and from the cooling module in the event of fault or power failure. The valves have a low pressure drop and are fast acting. The valves shall be Normally Closed (NC) operation and are supplied loose.</p>
<b>Rack Pressure Management</b>	<p>The OnRak shall be fitted with rack pressure management, which allows the differential pressure across the IT equipment to be monitored and controlled to achieve:</p> <ul style="list-style-type: none"> <li>• Positive air pressure at the server inlet.</li> <li>• Negative air pressure in the rear of the cabinet at the server outlet, to prevent backwash of hot air (behind OnRak coil guard).</li> <li>• Controlled differential pressure across the IT hardware so that air is not 'forced' through the IT equipment.</li> </ul>
<b>Room Mounted Temperature and Humidity Sensor</b>	<p>A room mounted temperature and humidity sensor shall be supplied loose for onsite fitment.</p>

## Dual Power Supply

Dual supply for redundancy and backup in the event of mains supply failure shall be provided. The dual power supply switch ensures that the OnRak always has an incoming power supply.

For the dual power supplies to operate effectively, the incoming power supplies must have the same voltage and frequency and be within 120° Phase Angle.

## Rack Mounted

The dual power supply changes from primary to the secondary within a period of 5ms (1/4 of a cycle)



## Under floor Dual Power Supply

Selection can be made to determine primary power supply.

The dual power supplies use C14 / C13 socket combinations for ease of use.

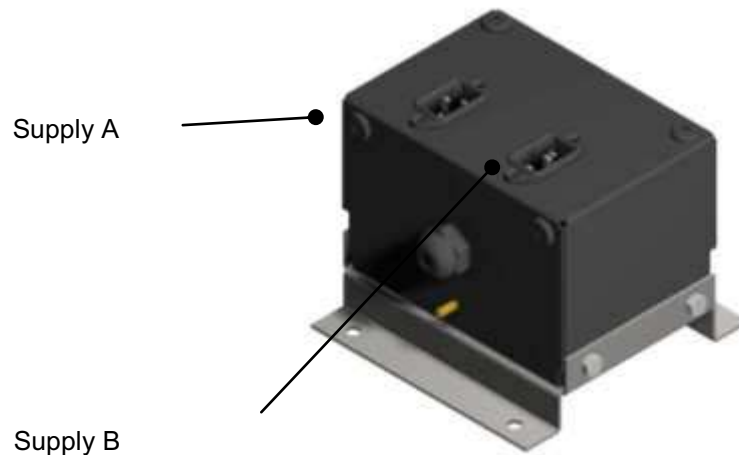

## Uninterrupted Power Supply

Uninterrupted power supply shall be supplied to enable power backup in the event of AC power loss. The UPS system ensures the OnRak can still maintain its cooling function. The UPS is available in 1U and 2U profiles.

## Static Transfer Switch

An ATS can be supplied allowing monitoring of primary power loss. With this loss detected a second power supply can be selected, and therefore resume power. Available in 2U profile.

## Technical Data

**IMPORTANT**  The following information is for general guidance; refer to the certified drawings provided for installation.

**CAUTION**  ALL work **MUST** be carried out by technically trained competent personnel.



The equipment contains live electrical and moving parts, ISOLATE prior to maintenance or repair work.

A fused and isolated electrical supply of the appropriate rating should be installed. As standard the equipment is designed for 230V  $\pm 10\%$ , 1 Phase, 50Hz to all relevant IEE regulations, British standards and IEC requirements.

## Design Parameters

The OnRak is designed for operation at air on dry bulb temperatures and water approach temperatures as standard:

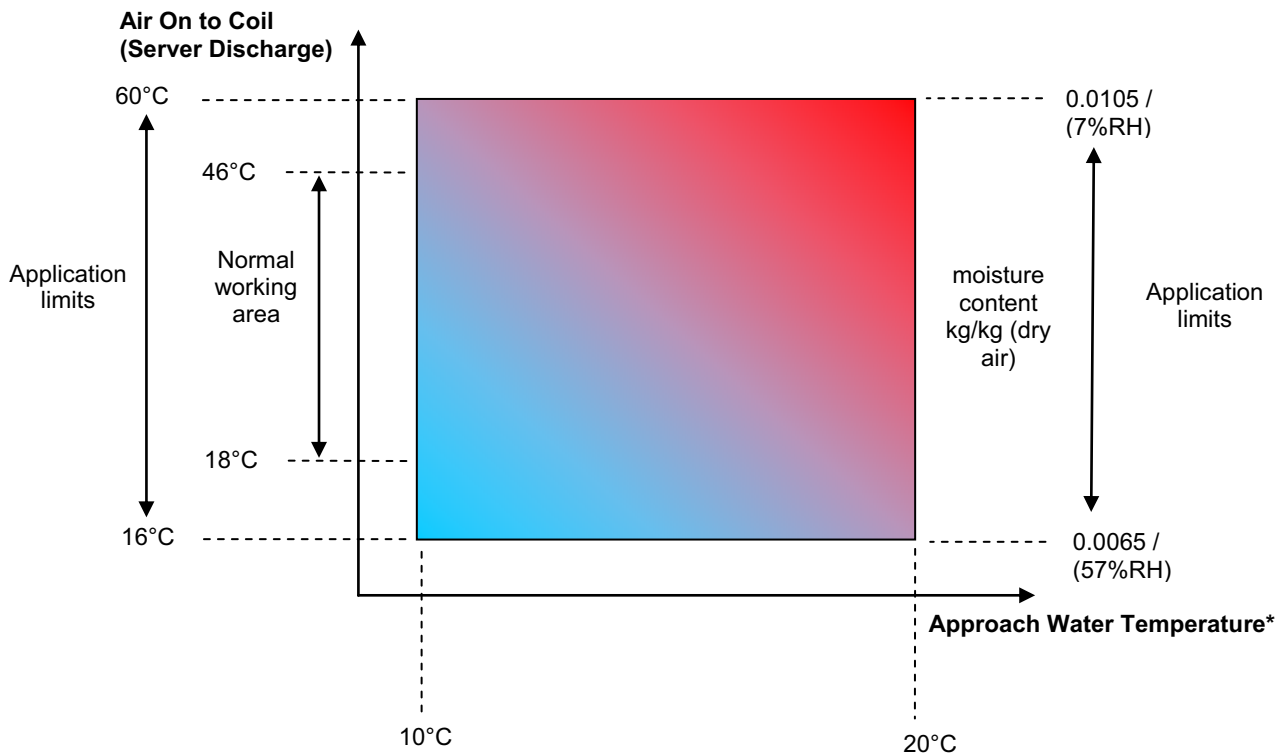

\* Minimum water temperature is always 2°C above the dew point temperature of the air

## Cooling Performance LOR 6042U-C028-0 (N+1 configuration, Fans at 75%)

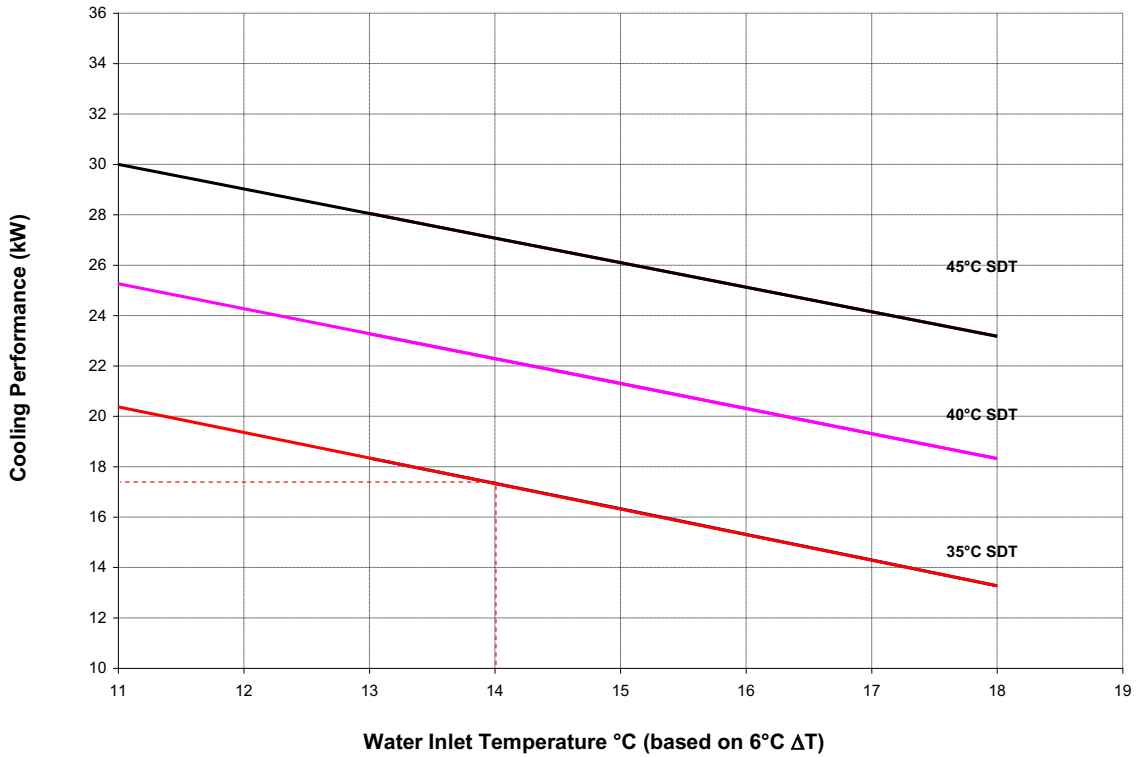

(1) At the design chilled water temperature project a line until it intersects with the Server Discharge Temperature (SDT), read off the cooling performance.  
 (e.g. 14°C projected up to 35°C SDT Line, reading across to 17.3kW.) All capacities based on water.

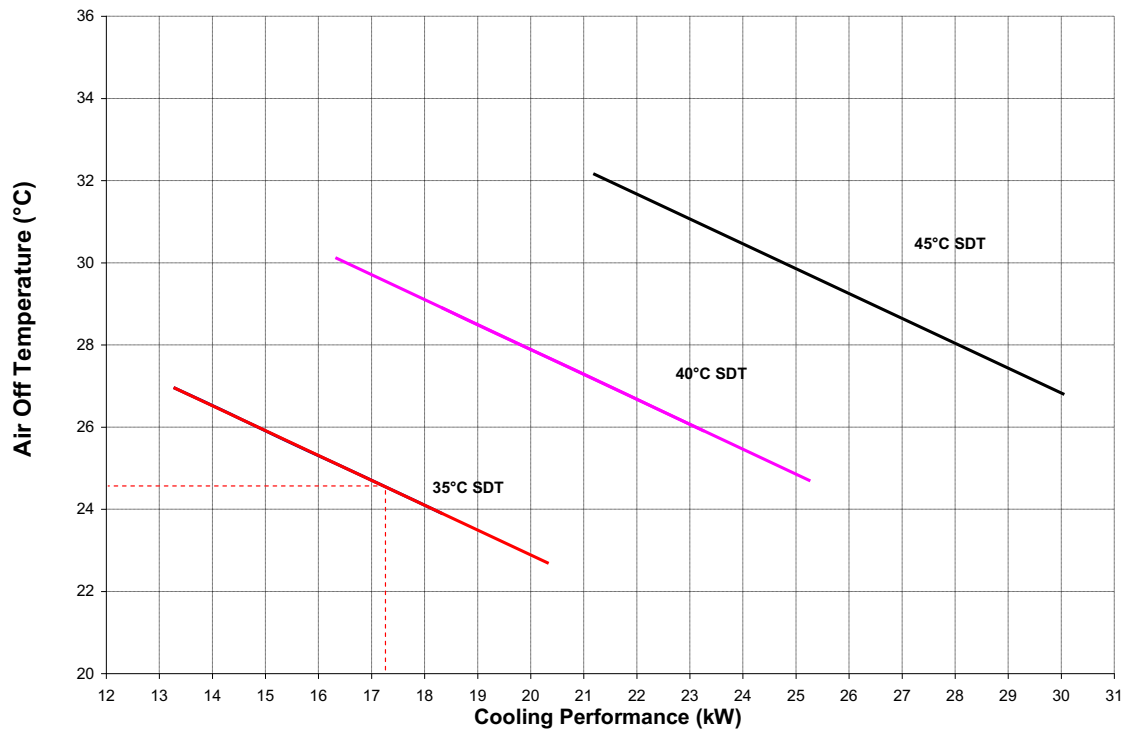

(2) Take the capacity, project a line to intersect the server discharge temperature (SDT) again and you can then read off the air off temperature. (E.g. 17.3kW projected up to 35°C SDT line, read across to air off temperature; 24.5°C).  
 All capacities based on water.

Cooling Performance LOR 6042U-C033-0 (N Configuration, Fans at 100%)

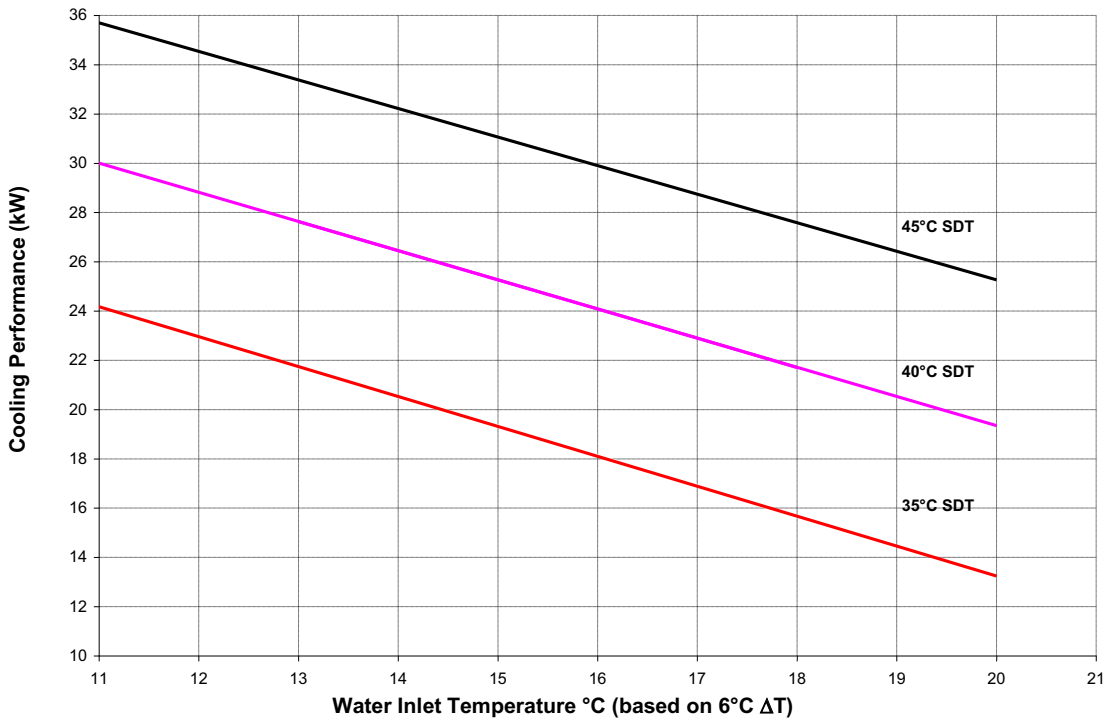

(1) At the design chilled water temperature project a line until it intersects with the Server discharge temperature (SDT), read off the capacity. All capacities based on water.

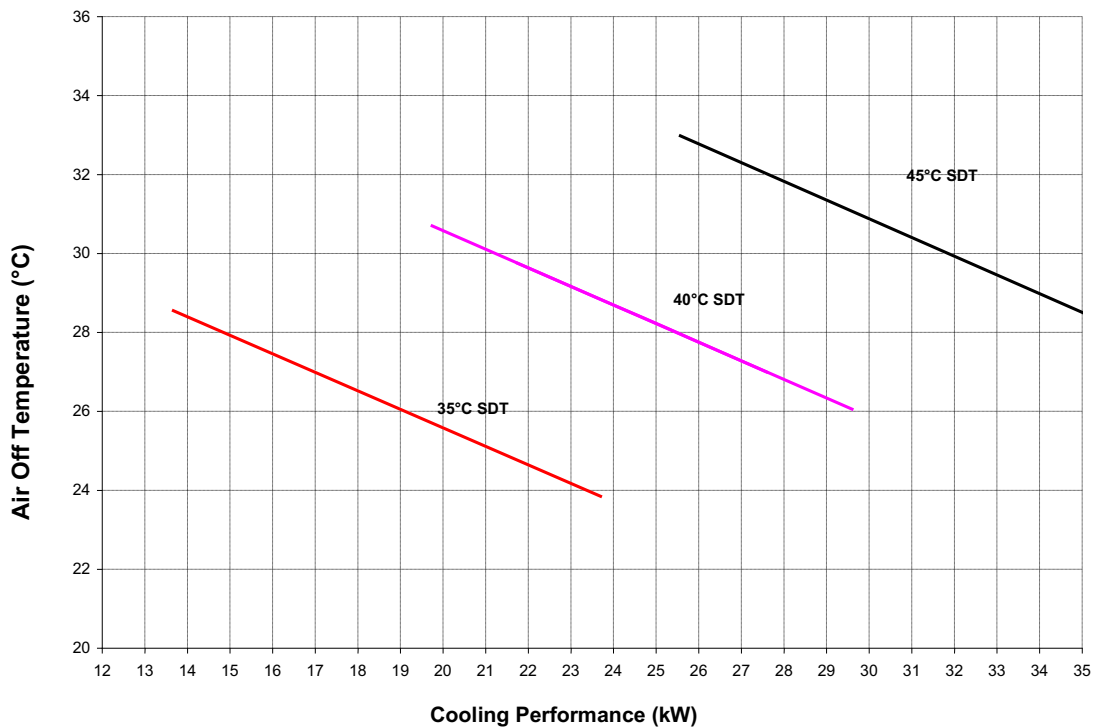

(2) Take the capacity, project a line to intersect the server discharge temperature (SDT) again and you can then read off the air off temperature. All capacities based on water.

**Cooling Performance LOR 8042U-C032-0 (N+1 configuration, Fans at 75%)**

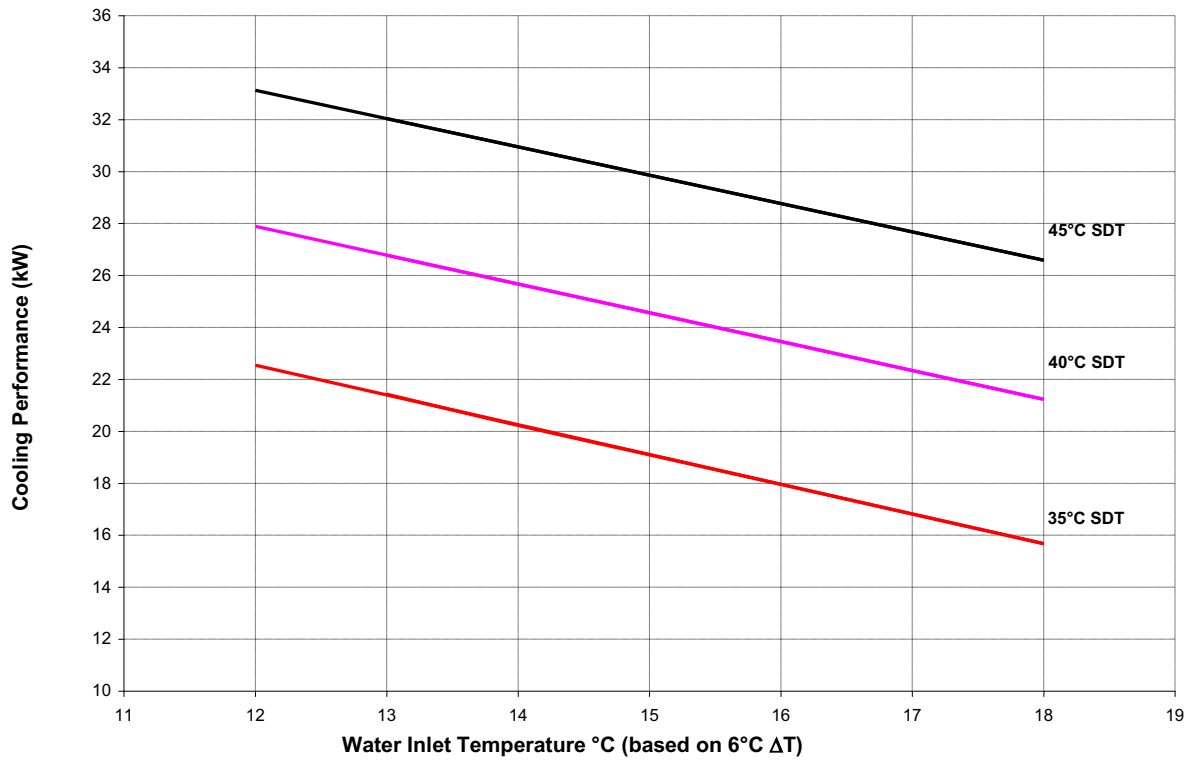

(1) At the design chilled water temperature project a line until it intersects with the Server discharge temperature (SDT), read off the capacity. All capacities based on water.

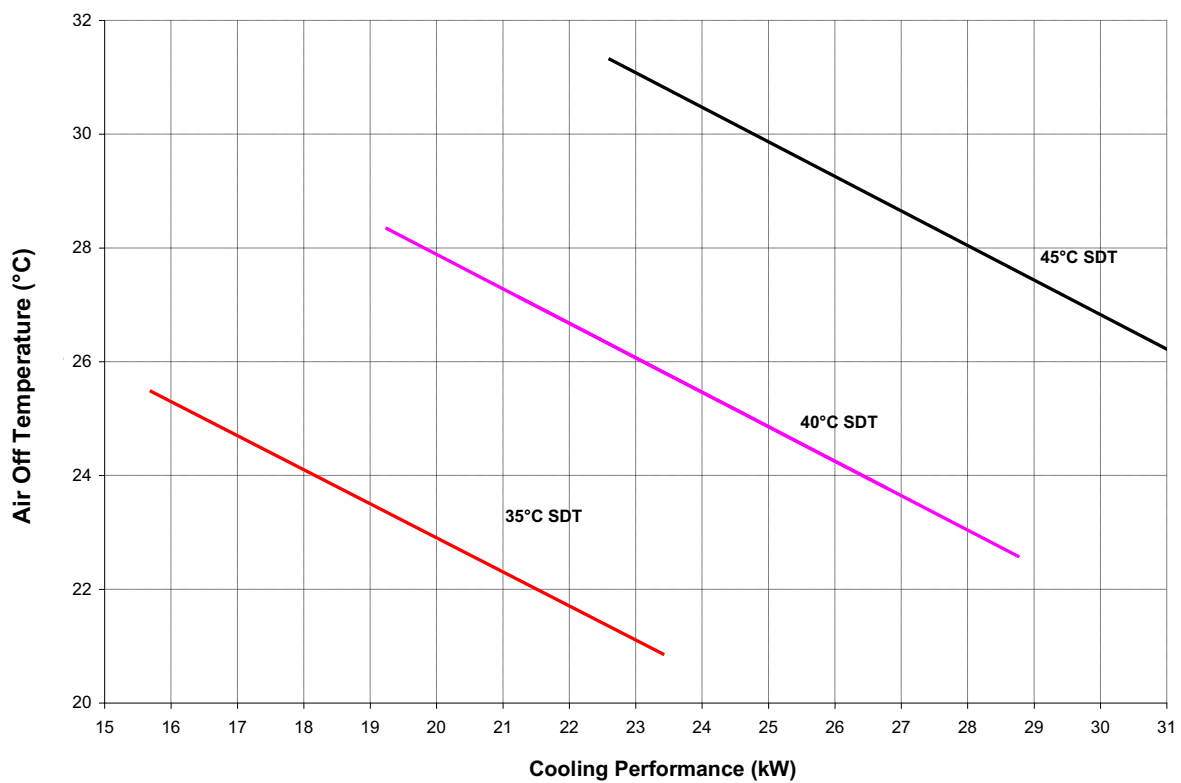

(2) Take the capacity, project a line to intersect the server discharge temperature (SDT) again and you can then read off the air off temperature. All capacities based on water.

## Cooling Performance LOR 8042U-C038-0 (N Configuration, Fans at 100%)

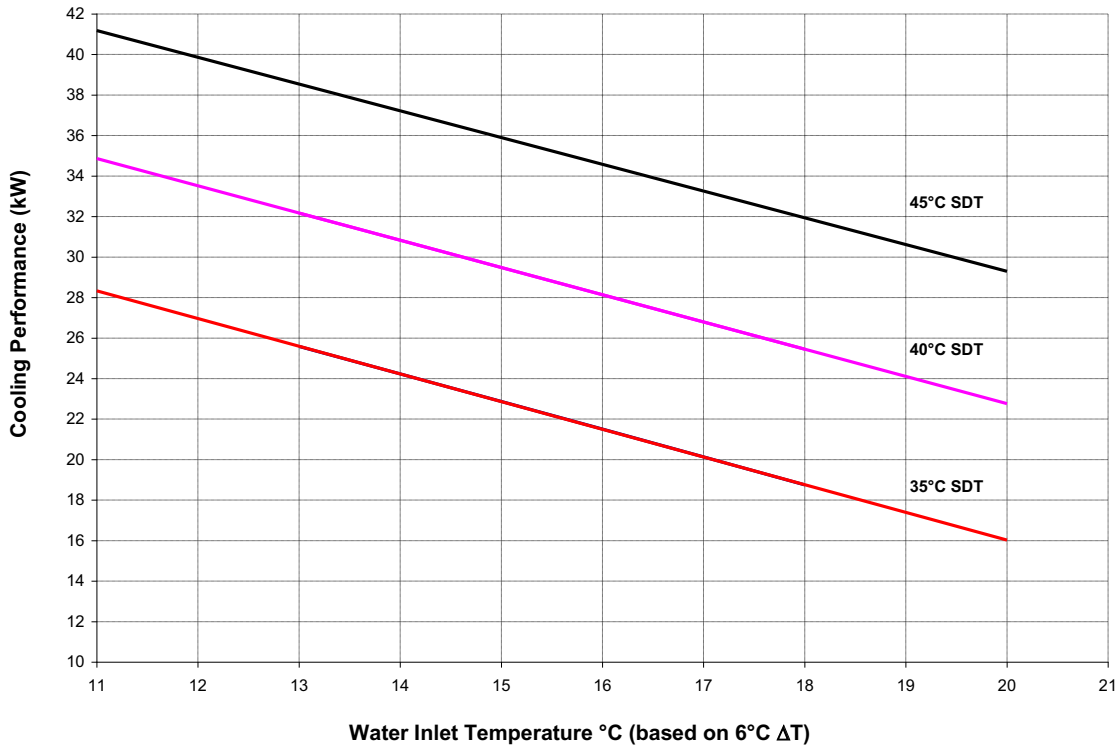

(1) At the design chilled water temperature project a line until it intersects with the Server discharge temperature (SDT), read off the capacity. All capacities based on water.

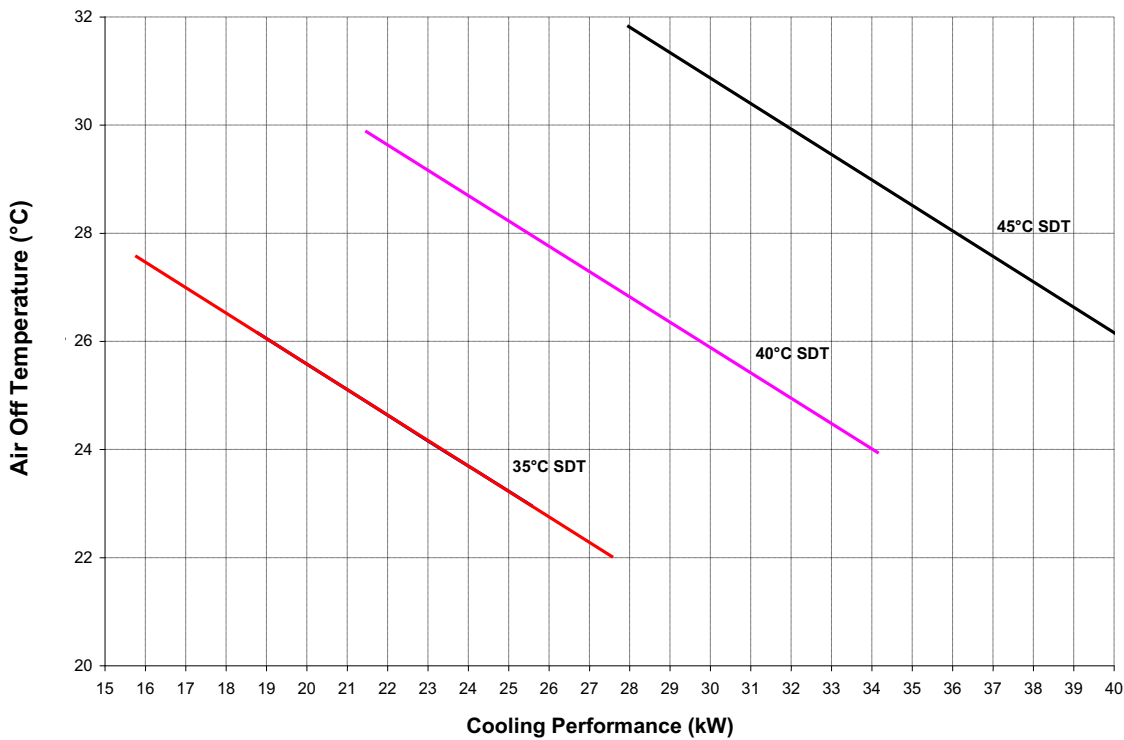

(2) Take the capacity, project a line to intersect the server discharge temperature (SDT) again and you can then read off the air off temperature. All capacities based on water.



## Ethylene Glycol Correction Factors

### Calculation of Design Volumetric Flow Rate (l/s)

The maximum design volumetric flow rate can be calculated using the following equation:

$$\dot{V} = \frac{Q}{\rho \times C_p \times \Delta T}$$

Where:

- Q = Cooling Capacity (kW).
- ΔT = Temperature Difference between Water/Glycol Entering/ Leaving (°C).
- ρ = Density of Glycol/Water mixture at design condition. Refer to table below.
- C<sub>p</sub> = Specific heat capacity at design condition. Refer to table below.

### Calculation of Indoor Unit Pressure Drop (ΔP<sub>S</sub>)

The maximum indoor unit pressure drop can be calculated using the following equation:

$$\Delta P_S = \Delta P_W \times P_\chi$$

Using the volumetric flow rate calculated above, the pressure drop (ΔP<sub>W</sub>) can be taken from the relevant pressure drop graph..

Where:

- ΔP<sub>S</sub> = Maximum Water/Glycol Pressure Drop for the indoor unit (kPa).
- ΔP<sub>W</sub> = Equivalent Water Pressure Drop for indoor unit (kPa).
- P<sub>χ</sub> = % Glycol Pressure Drop Correction Factor @ 10°C Water Temperature. Refer to table below.



**The resultant pressure drop (ΔP<sub>S</sub>) is the maximum pressure drop based on the indoor unit running at the prescribed conditions.**

**This will typically occur when the water/glycol temperature is approximately 10°C.**

**The indoor unit pressure drop will change at other operating conditions.**

### Specific Heat Capacity (C<sub>p</sub>)

Water/Glycol Temperature °C	Ethylene Glycol (Volume) / Freezing Point °C				
	0% / 0°C	10% / -4°C	20% / -9°C	30% / -15°C	40% / -23°C
	C <sub>p</sub>	C <sub>p</sub>	C <sub>p</sub>	C <sub>p</sub>	C <sub>p</sub>
10	4.193	4.064	3.918	3.773	3.606

### Density (ρ)

Water/Glycol Temperature °C	Ethylene Glycol (Volume) / Freezing Point °C				
	0% / 0°C	10% / -4°C	20% / -9°C	30% / -15°C	40% / -23°C
	ρ	ρ	ρ	ρ	ρ
10	998	1008	1018	1027	1037

### Pressure Drop Correction Factor (P<sub>χ</sub>)

Water/Glycol Temperature °C	Ethylene Glycol (Volume)				
	0%	10%	20%	30%	40%
	P <sub>χ</sub>	P <sub>χ</sub>	P <sub>χ</sub>	P <sub>χ</sub>	P <sub>χ</sub>
10	0.983	1.0125	1.027	1.045	1.067

(1) All data based upon ASHRAE fundamentals 2001.

## Mechanical Data

			LOR6042U-C028-0	LOR6042U-C033-0	LOR8042U-C032-0	LOR8042U-C038-0
Dimensions - H x W x D		mm	2030 x 600 x 203	2030 x 600 x 203	2032 x 800 x 213	2032 x 800 x 213
Weight - Machine – Operating		kg	65 75	65 75	96 110	96 110
Construction			Sheet steel, epoxy baked powder paint			
Material/ Colour			RAL 7021 (Black Grey)			
Nominal Air flow		m³/s	1.4	1.8	1.4	1.8
Fan redundancy			N+1	N	N+1	N
Gross Total cooling Capacity	(1)	kW	28.1	33.4	32.0	38.5
Fan gains		W	161	306	161	306
EER			175	109	199	126

(1) Based upon a server discharge temperature of 45°C. Water on 13°C, Water off 19°C. 100% water  
All performance data is supplied in accordance with BS EN 14511-1:2013

## Electrical Data

			LOR6042U-C028-0	LOR6042U-C033-0	LOR8042U-C032-0	LOR8042U-C038-0
Nominal Run Amps	(1)		1.35	1.52	1.35	1.52
Maximum Run Amps	(1)		1.62	1.62	1.62	1.62
Recommended Mains Fuse Size		A	10	10	10	10
Mains Supply		V	230	230	230	230
Control Circuit		VAC	24	24	24	24
Motor Type			EC Axial			
Quantity x Motor Size		W	4 x 72	4 x 72	4 x 72	4 x 72
Power input		W	161	306	161	306

(1) Measured on a basic unit including 3 way valves.

Note: Earth Leakage current from the OnRak may exceed 3mA

## Waterside Pressure Drop

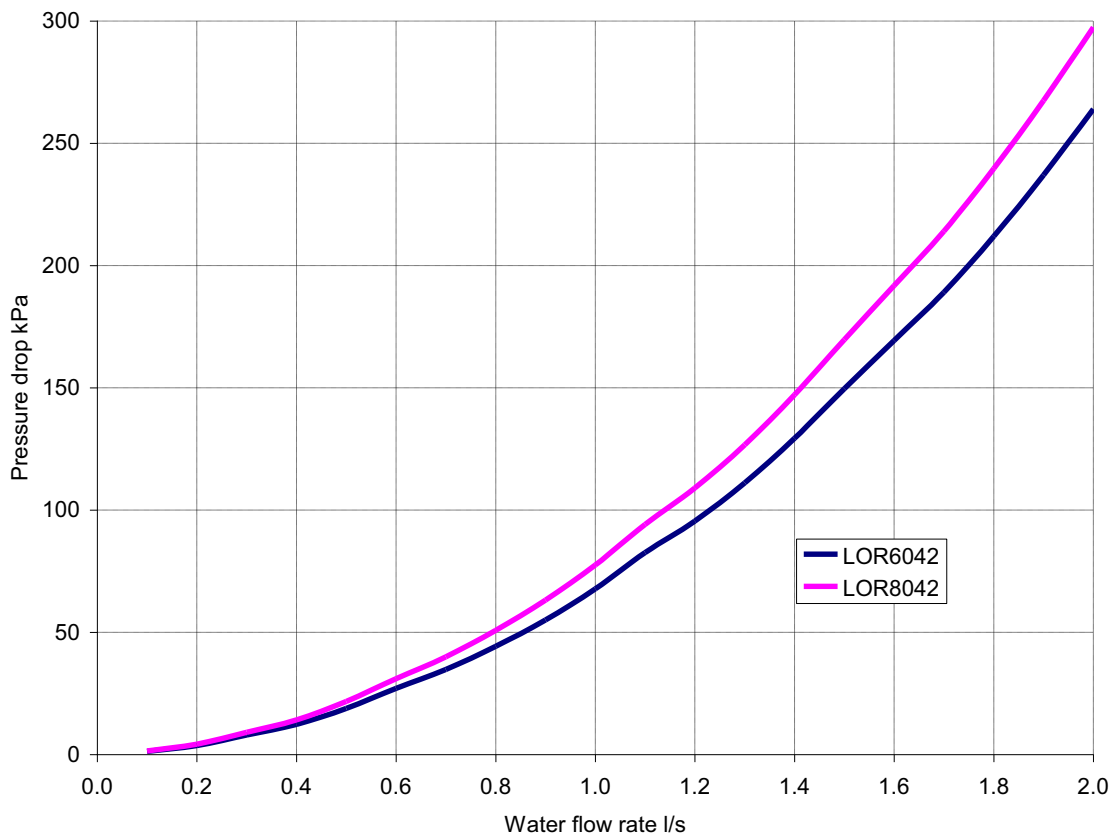

Coil, Hose and Valve Pressure Drop Only

## Dimensional Data

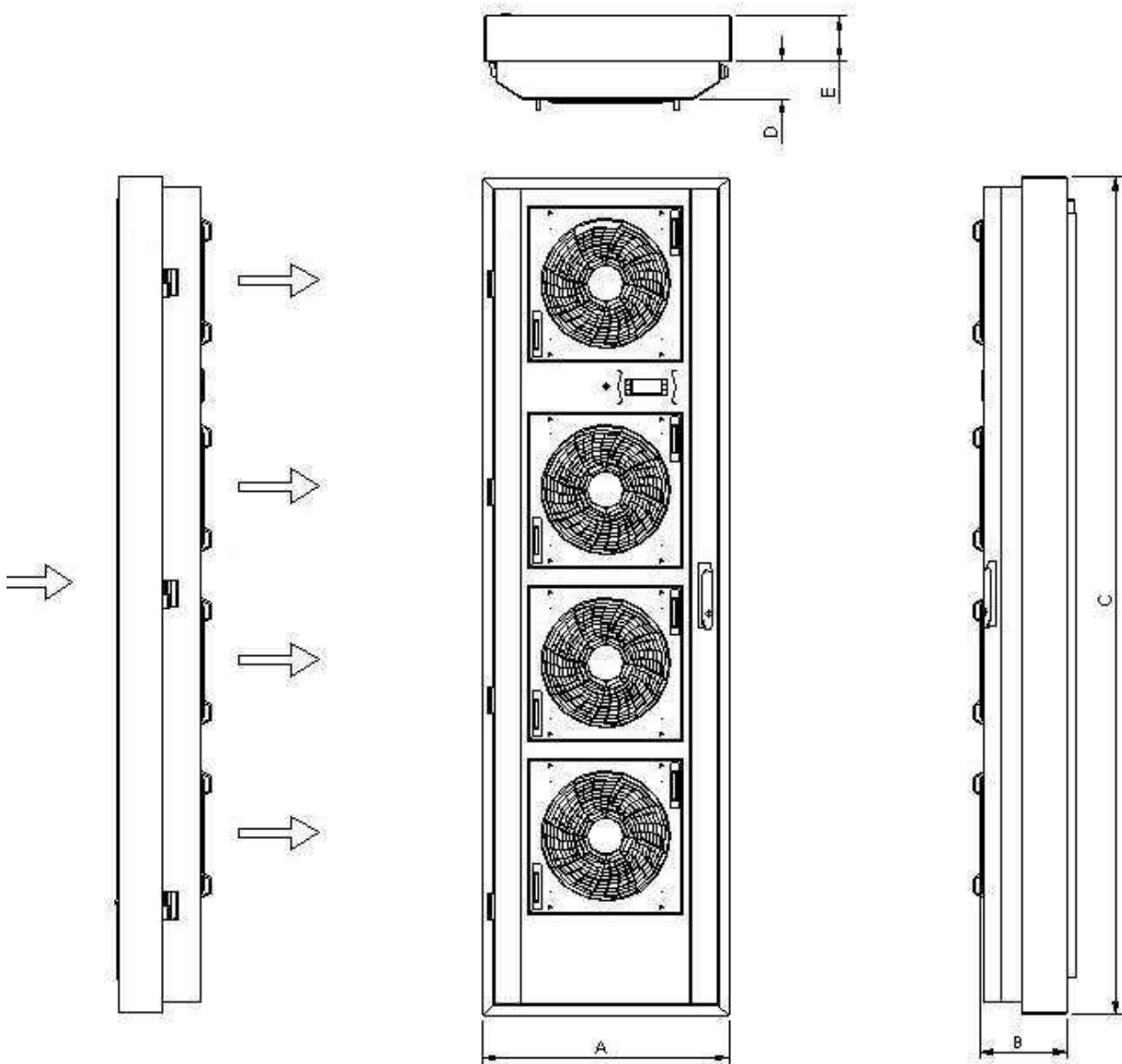

		Dimensions				
		A	B	C	D	E
LOR 600	mm	600	210	2030	90	110
LOR 800	mm	800	213	2032	103	110

## Component Masses

		LOR 600	LOR 800
	mm		
Door	kg	65	
Mating frame	kg	28	
Fans	kg	5	5

## Sound Measurement Method

### Measurement of Sound Data

All sound data quoted has been measured in the third-octave band limited values, using a real time analyser calibrated sound intensity meter in accordance with BS EN ISO9614 Part 1: 1995.

All sound power levels quoted are calculated from measured sound intensity according to BS EN ISO9614 Part 1: 1995.

### Semi Hemispherical

Sound pressure levels are calculated from sound power using the semi-hemispherical method where the noise source is in junction with 1 boundary i.e. the floor.

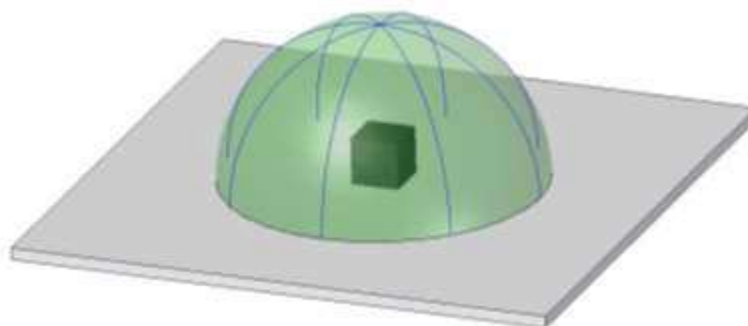

### Free Field

For comparison, the semi hemispherical figures can typically be reduced by 3dB to provide free field conditions.

**Specialist acoustic advice is recommended for noise critical applications.**

## Noise Data

LOR 6042U-C028-0

Frequency (Hz)	Overall	63	125	250	500	1000	2000	4000	8000
Sound Pressure @ 1m dB(A)	62	35	43	48	58	57	55	51	39

LOR 6042U-C033-0

Frequency (Hz)	Overall	63	125	250	500	1000	2000	4000	8000
Sound Pressure @ 1m dB(A)	67	42	46	53	61	62	60	56	47

LOR 8042U-C032-0

Frequency (Hz)	Overall	63	125	250	500	1000	2000	4000	8000
Sound Pressure @ 1m dB(A)	62	35	43	48	58	57	55	51	39

LOR 8042U-C038-0

Frequency (Hz)	Overall	63	125	250	500	1000	2000	4000	8000
Sound Pressure @ 1m dB(A)	67	42	46	53	61	62	60	56	47

## Pipework Schematics

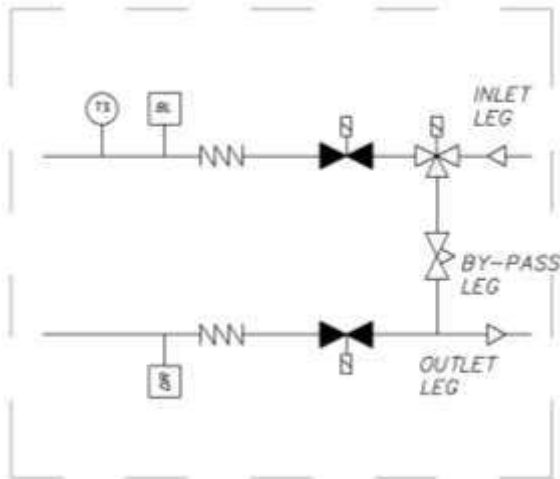

Scheme 1

- 3 way chilled water valve
- Bypass balancing valve
- Normally closed solenoid valves
- Threaded pipe connections

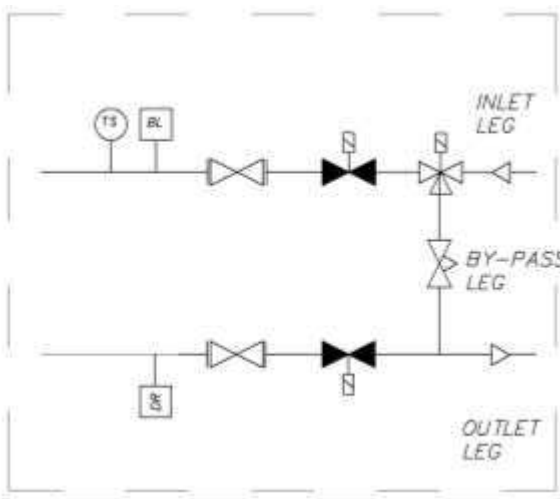

Scheme 2

- 3 way chilled water valve
- Bypass balancing valve
- Normally closed solenoid valves
- Quick connector

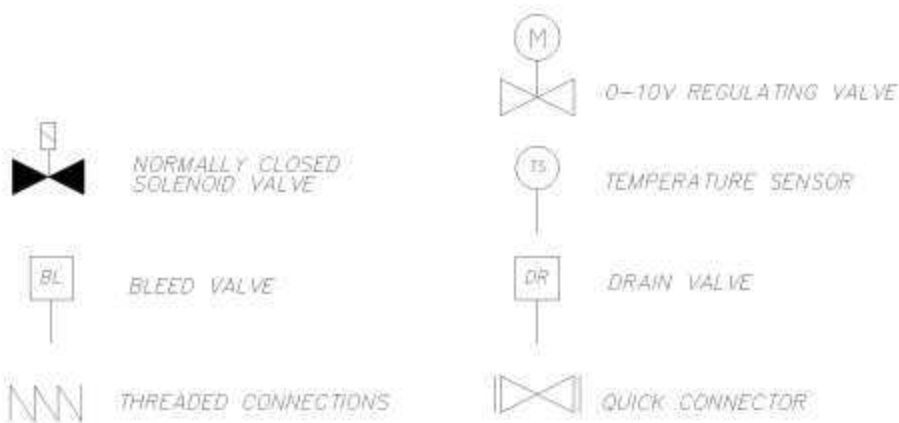



## Installation

### IMPORTANT

▼ If the unit is dropped, it should immediately be checked for damage and reported to Airedale.

### Installer Responsibilities

It is the responsibility of the installer to complete the following processes prior to commissioning of the unit.

### Positioning



The mating frame is attached to the customers rack. An air tight seal must be placed between the mating frame and the data enclosure.

The OnRak is then lifted onto the hinges and as it's closed will produce an air tight seal.

### CAUTION

▼ Airedale will accept no responsibility for mishandling during the positioning of the equipment. The data rack must be mounted level.

### IMPORTANT

▼ Ensure that the OnRak, the mating frame and data rack are earth bonded together.



## Fitting Hinges

The OnRak needs to be lifted vertically to ensure that the assembly fits onto the hinges. Care must be taken whilst locating the lift-off hinges together prior to lowering into place.

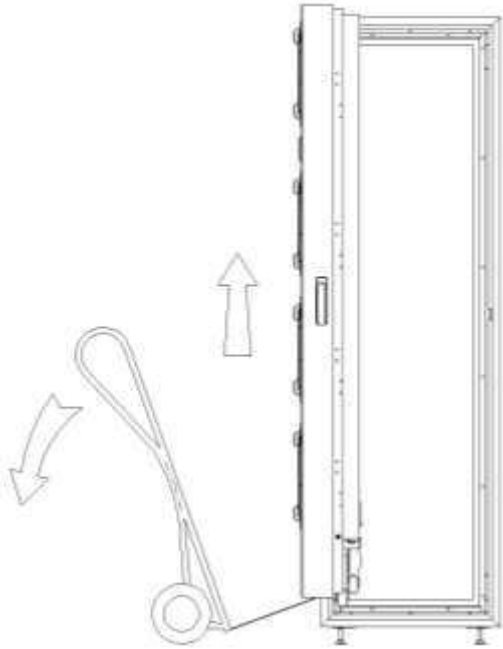

Illustrations for guidance only

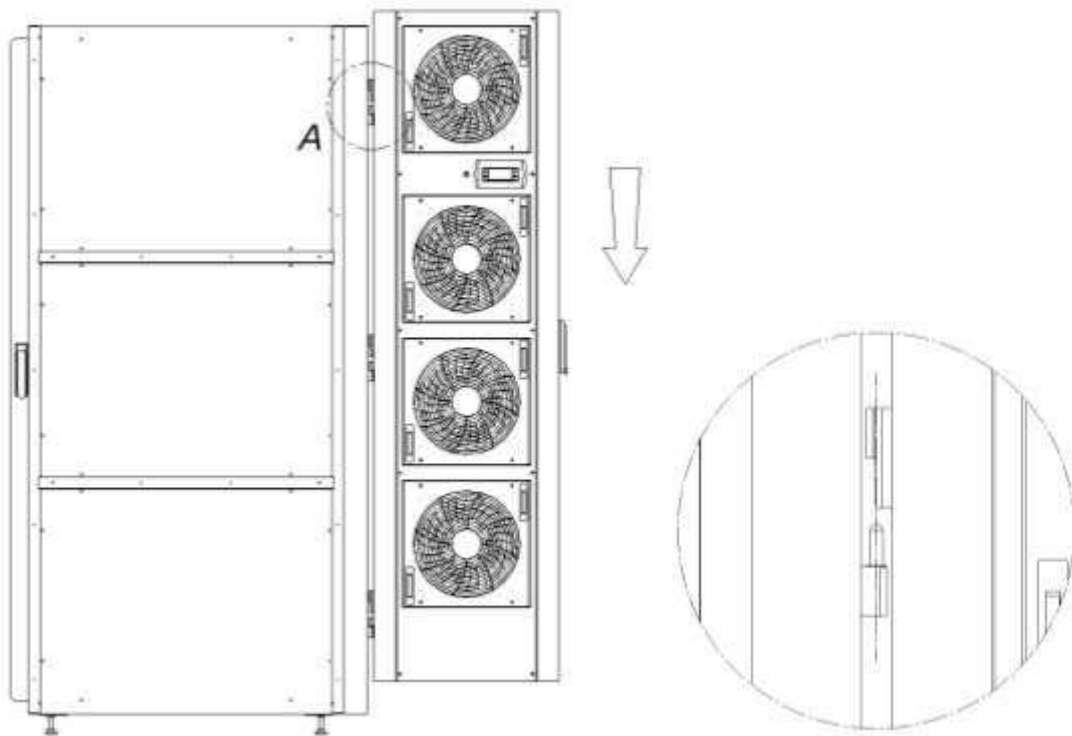

## Data Rack Feet

The data rack feet must be used prior to the unit being mounted to the rack. This takes the weight off the castors. The Data rack feet must be secured to the floor to avoid unnecessary movement during operation.

## Rack Support Wheel

A support wheel is provided for fitment under the Onrak door. This is to be at the same level as the door rack feet. The wheel is to be fitted ensuring that it has free movement.

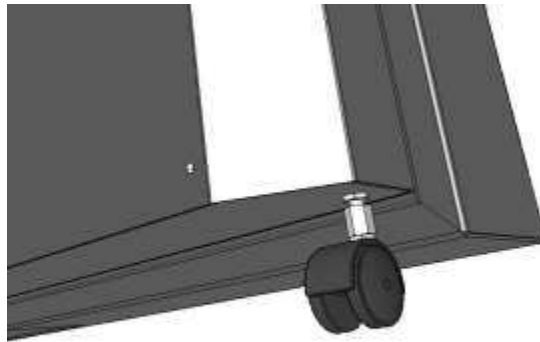

## Wheel Adjustment

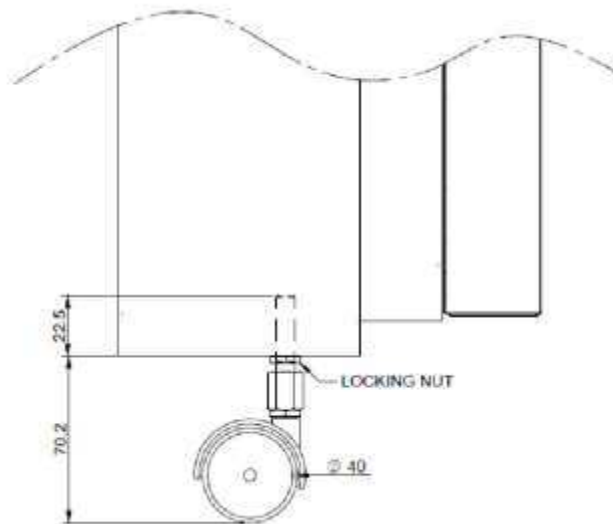

The castor can be adjusted by the following procedure

- Slacken locking nut
- Rotate castor to desired height Min 70mm, Max 87mm
- Tighten Locking Nut

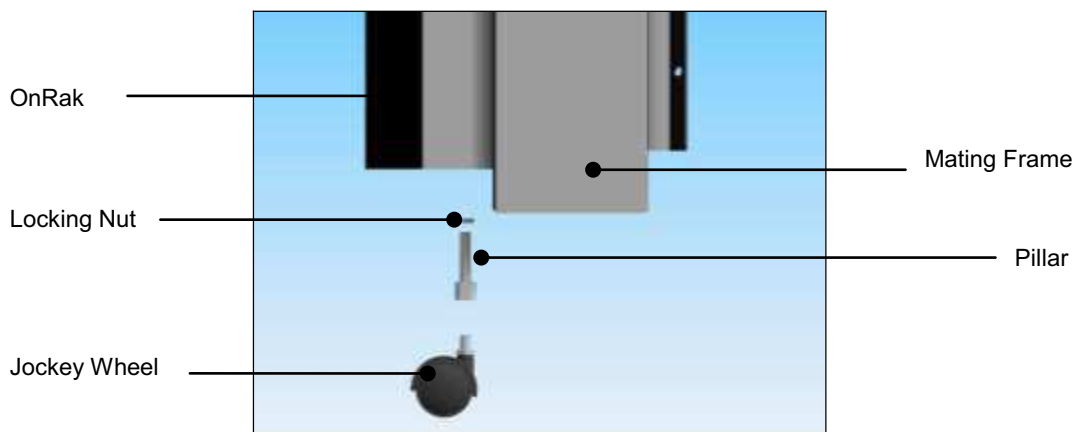

## Door Latch Mechanism

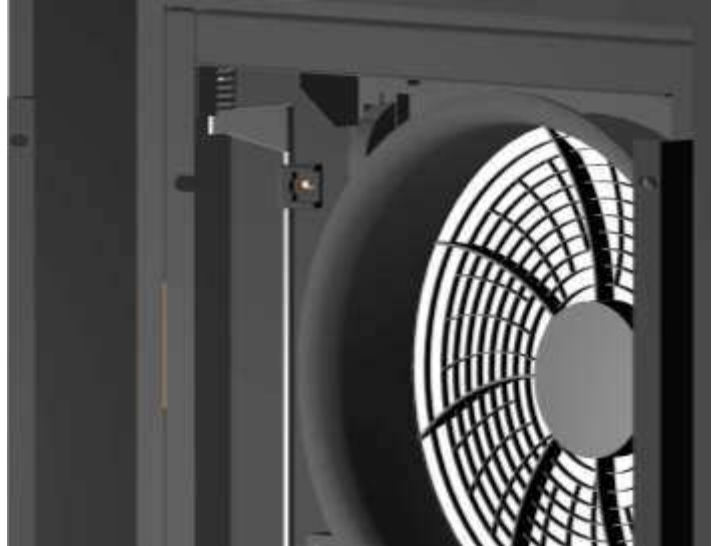

### CAUTION



Ensure that the door latch mechanism does not snag on the sheet metal. Distortion of the door can occur if the latch is forced

## Floor Cut Outs

To enable the flexible pipework installation the following minimum cut out is required in the floor tile below the unit. Contact your grommet supplier for exact sizes. This ensures that the pipework does not get obstructed causing additional strain on the fittings.

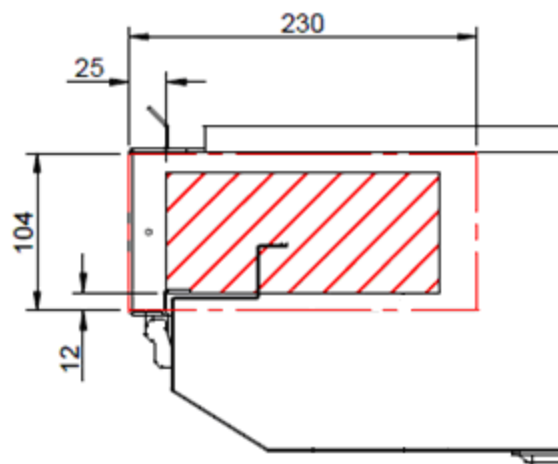
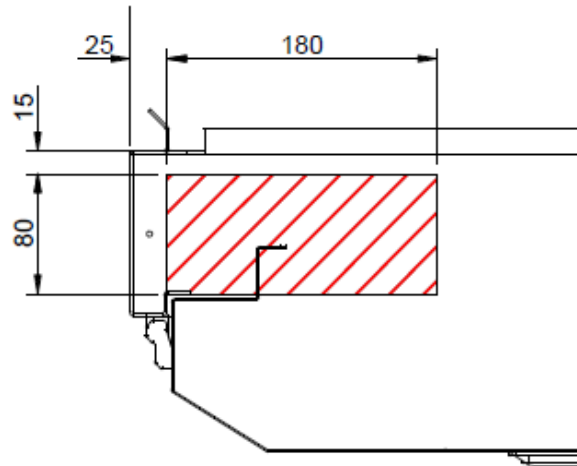

- Floor Tile Cut Out Dimension (Minimum)
- Mating Frame Cut Out

## IMPORTANT

Ensure that the mating frame and floor is sealed for correct unit operation.



Integral Raised-Floor Grommet

Mini Split Integral Grommet



## Water Connections

Two flexible, stainless steel braided hoses connect the coil to the chilled water supply.

The flexibility of the hoses allows the OnRak door to be easily opened for accessing hardware within the server cabinet, without the need to disconnect services or disrupt cooling..

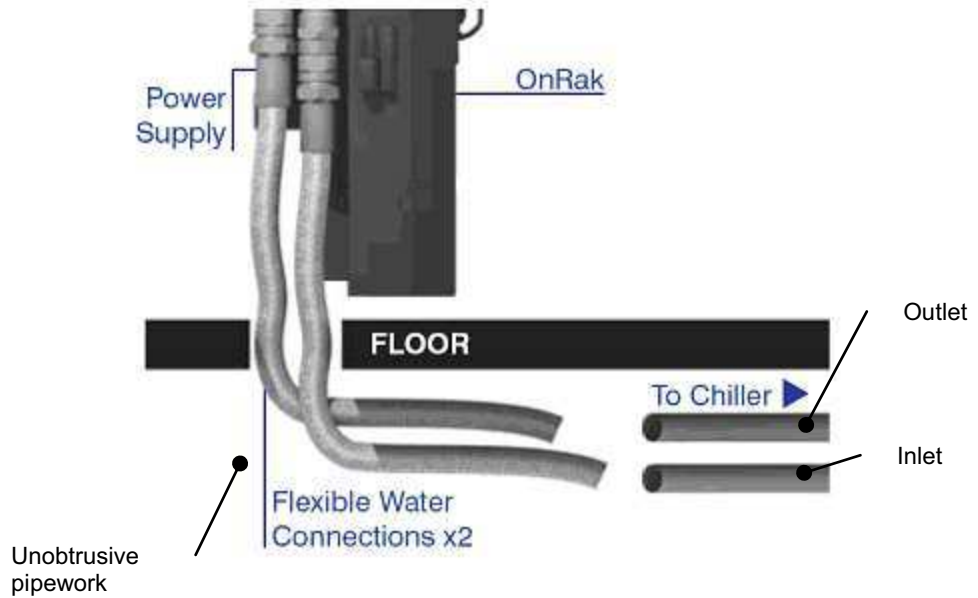

Additional pipework components are then installed under the server room floor.

The flexible water pipework has a swivel connection (which becomes rigid when tight) that is installed under the floor. A nipple is supplied for this fitment with male or female connections.

The fixed end of the flexible water pipework is connected to the coil into a swivel coupling.

## Flexible Water Connection

### Pipework Sweep

The stainless steel braided must be installed so that the hose has unobtrusive movement in either fully opened or closed positions

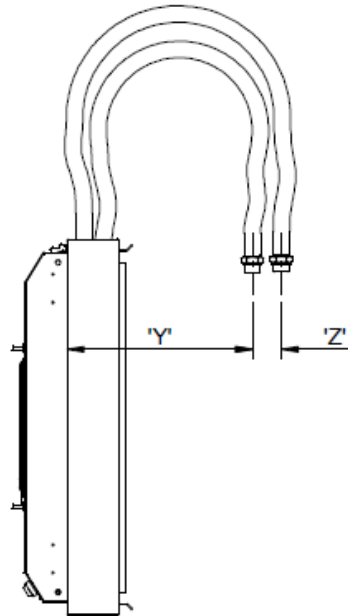

Plan View

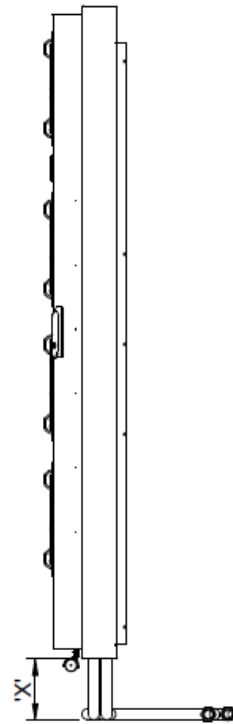

Side View

### Recommended Dimensions

- X = Floor Void Depth
- Y = 500mm
- Z = 110mm

Minimum recommended hose length  $X + 1m$   
(Hoses available as standard in 1.5m and 3m lengths)

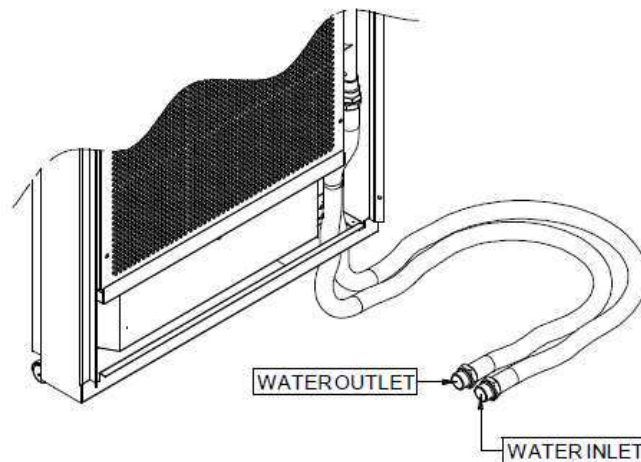

## Compression Fittings

The recommended method of using compression fitting is as follows:-

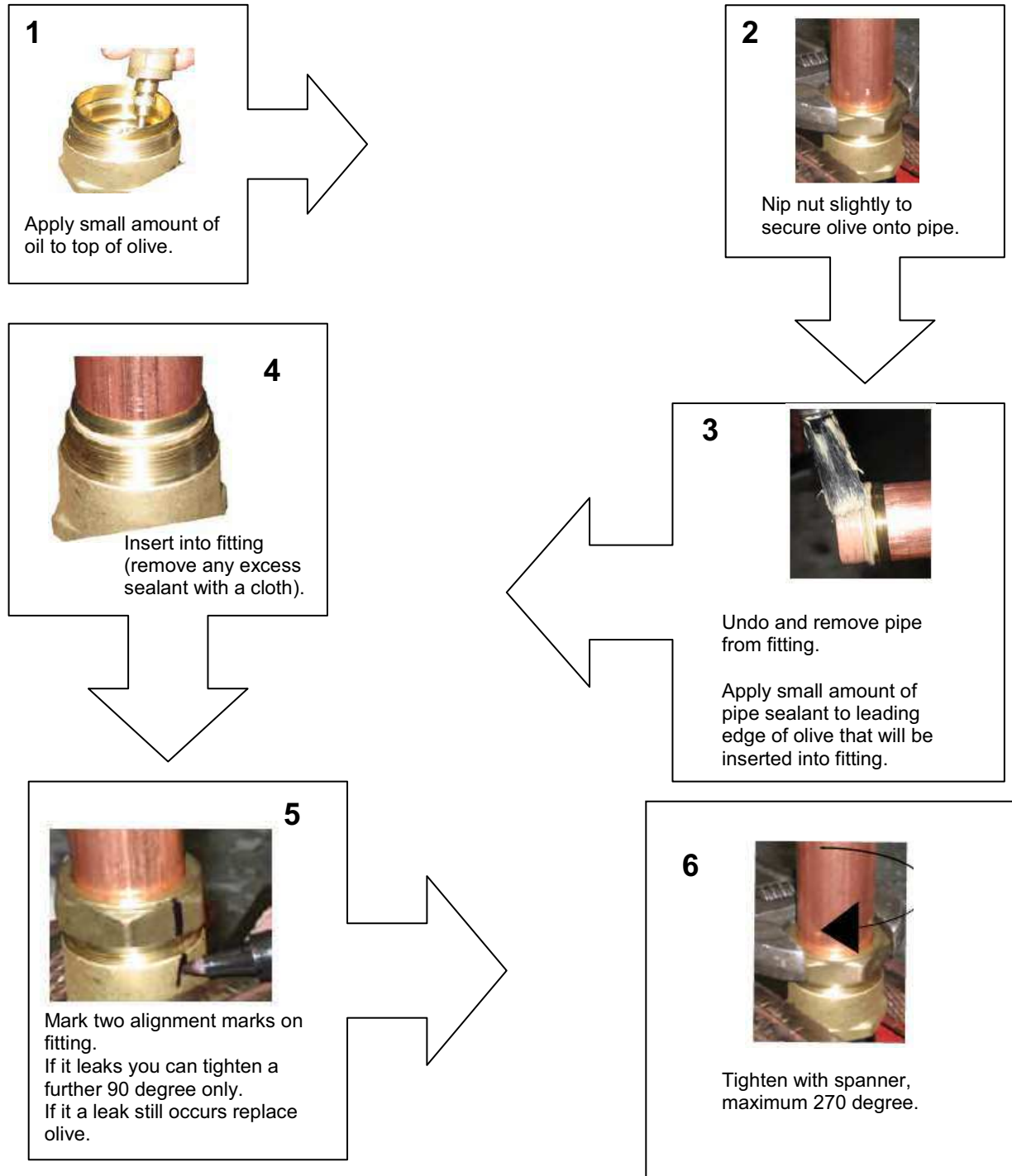

### IMPORTANT CAUTION



The above method is for advice only.  
**Over tightening can cause the compression fittings to fail.**

**If you are applying heat around any compression fitting it is recommended that the pipe is kept cool with a wet rag. This ensures that the pipe does not become soft. If the pipe gets soft the olive cannot compress onto the pipe.**

**Airedale will not be held responsible for any water leaks by compression fitting misuse.**

## Chilled Water Valve (3 Way)

The chilled water valve has an indication of flow on the stem. The actuator is securely attached to the top of the valve so that when there is a demand for cooling the valve opens allowing water to flow through the coil. No demand, the water goes through the bypass (0 VDC no demand, 10 VDC 100% demand).

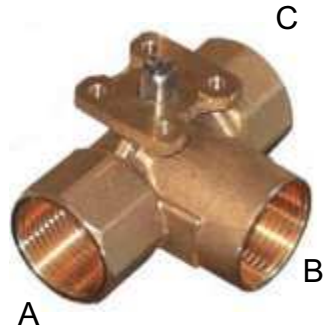

- (A) Flow to coil
- (B) Bypass leg
- (C) Common

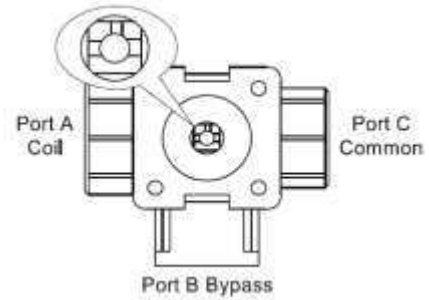

Valve in full flow to coil (C to A)

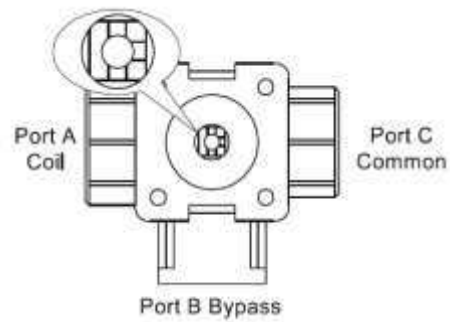

Valve in flow to bypass (C to B)

## Valve Actuator Orientation

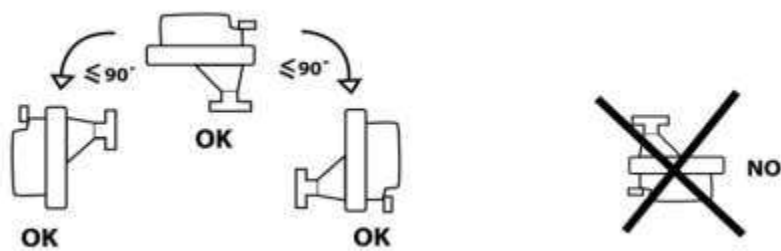

## CAUTION

**▼** The chilled water valve electrical connection must be a maximum of 3m away from the customer terminal box. This is to ensure EMC Compatibility.



## Chilled Water Valve (2 Way)

The chilled water valve has an indication of flow on the stem.

The actuator is securely attached to the top of the valve so that when there is a demand for cooling the valve opens allowing water to flow through the coil. No demand, the water is shut off allowing no water to enter the coil (0 VDC no demand, 10 VDC 100% demand).

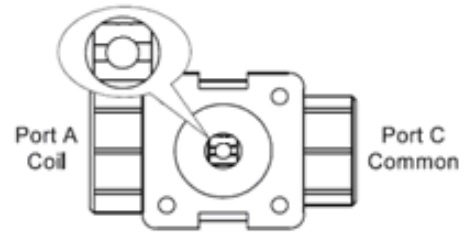
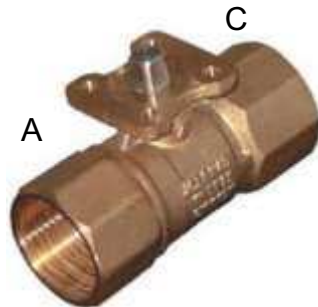

Valve in full flow to coil (C to A)

(A) Flow to coil  
(C) Common

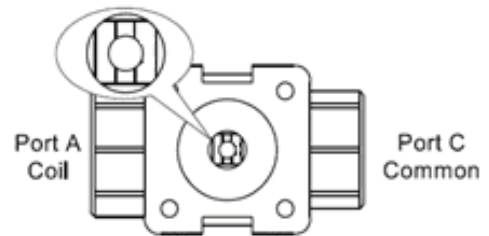

Valve in shut off mode

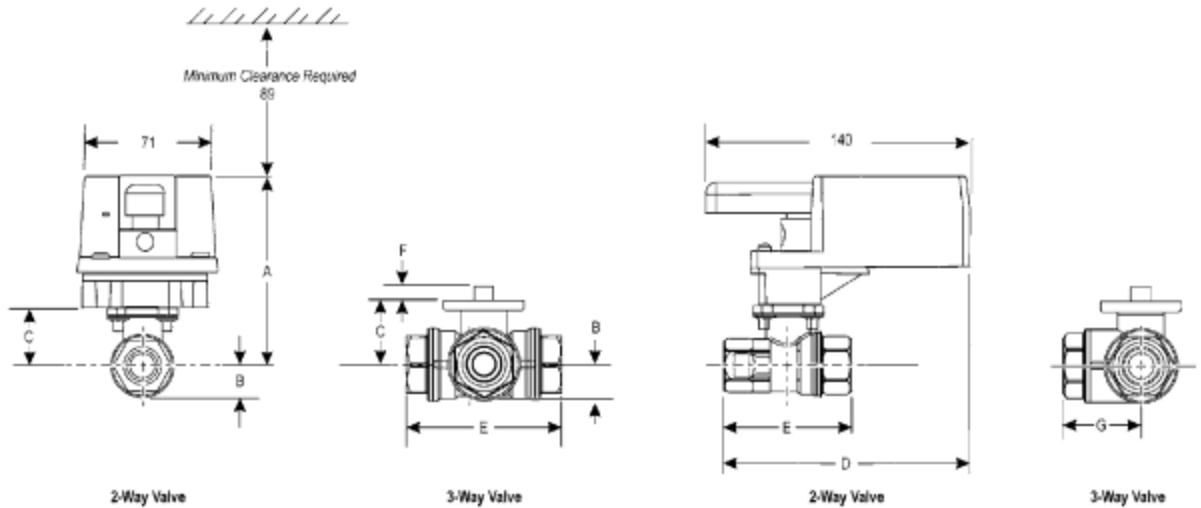

Valve connection sizes 1" BSP.

A	B	C	D	E	F	G*
100	19	33	141	87	9	43

\* for 3 way valves only

### CAUTION



The chilled water valve electrical connection must be a maximum of 3m away from the customer terminal box. This is to ensure EMC Compatibility.

## Solenoid Valve

The solenoid valve can be installed in any position, vertical with coil upwards preferred.

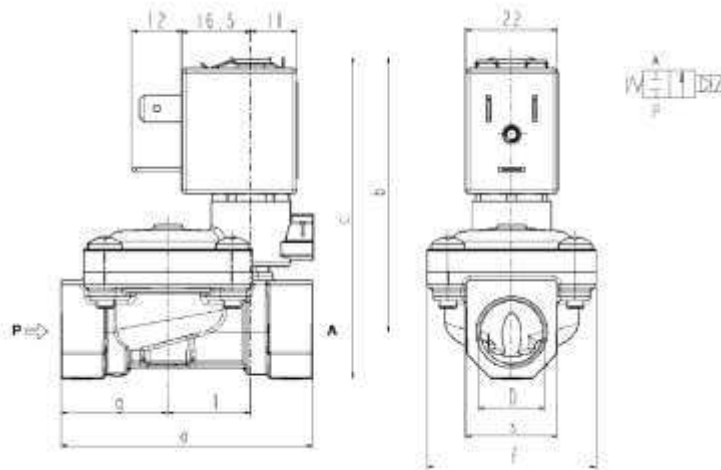

Mass 1kG

a	b	c	f	g	l	s
105	85	106	71	46	28	42

## CAUTION



The solenoid valve electrical connection must be a maximum of 3m away from the customer terminal box. This is to ensure EMC Compatibility.

## Coil Water Connections

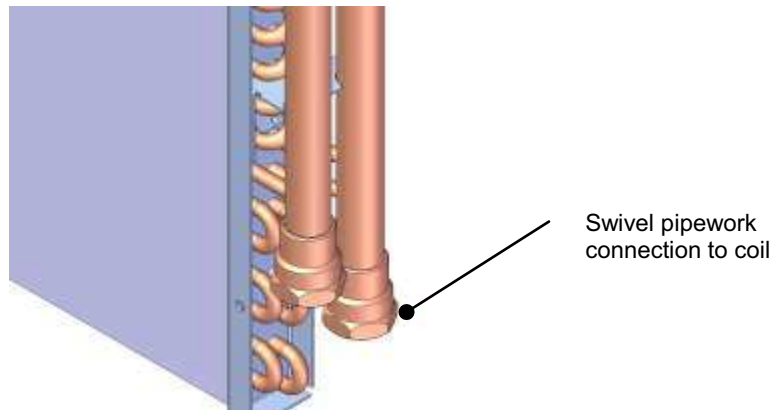

Coil connections are brazed at Airedale. Full pressure testing to 20Barg is carried out prior to unit despatch.

## Water Temperature Sensor

The water temperature sensor is attached to the inlet water pipework with a copper strap. It is factory fitted although if you are replacing the sensor ensure that it's fixed securely.

**Customer Terminal Box** The customer terminal box is attached to the coil guard during shipment. Carefully remove this and feed the box through the hole in the mating frame and floor tile cut-out. This must be done after the door is fitted to the mating frame.

**Dual Power Supply** The dual power supply can be either fitted into a rack or fitted in the floor void under the server rack. The following procedures apply.

**CAUTION**  The dual power supplies must be electrically earth bonded. (Earth stud fitted to back of power supply)

### Rack Mounted



Selection can be made to determine primary power supply by using the centre selection switch..



- Attach the earth strap to the rear of the power supply unit.
- Locate the Dual power supply between the cable support guides of the server rack.

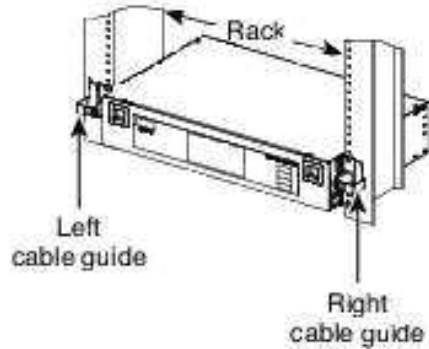

- Secure the unit with screws supplied by your rack manufacturer.
- Attach the incoming fused power supplies.
- Fit power supply retaining clips.
- Attach the outgoing power supply to the customer terminal box.

## IMPORTANT



Do not route the outgoing cable through the area occupied by the pipework. The recommended location is through the PDU trunking to the customer terminals.

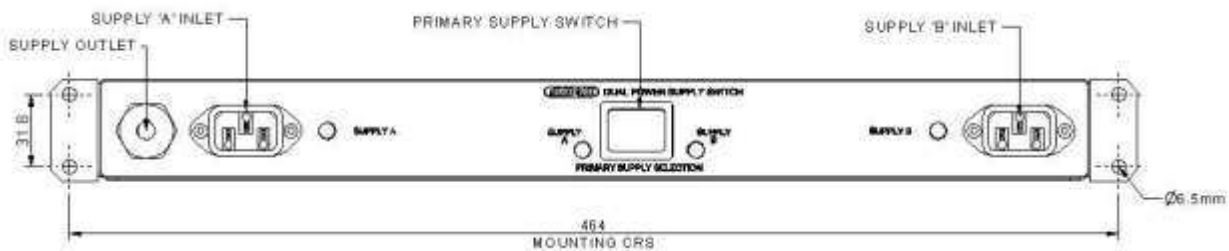

## LED Indicators

The LED's fitted to the rack indicate the following

	ON	OFF
Green A	Supply Live A	No Power
Green B	Supply Live B	No Power
Blue A	Primary supply selected A	Supply not selected
Blue B	Primary supply selected B	Supply not selected

## Under Floor Dual Power Supply

The under floor Dual Power supply is located under the floor void. The supply is to be mounted securely. Provision is made for fixing to the floor or associated supports.

- Attach relevant earth bonding to the power supply.
- Attach the incoming fused power supplies. (The Primary supply for this supply is always "A".)
- Fit power supply retaining clips.
- Attach the outgoing power supply to the customer terminal box.

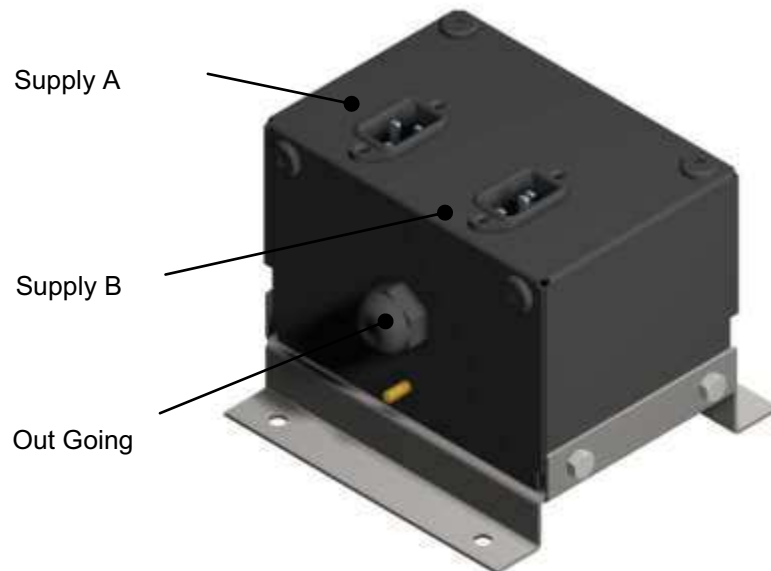

The dual power supplies use C14 / C13 socket combinations for ease of use.

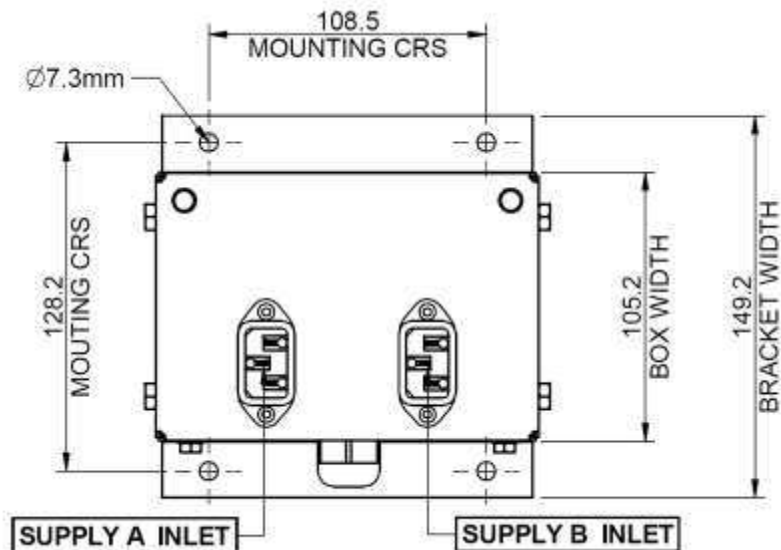

**CAUTION**

The OnRak must have relevant over current protection (MCB's) upstream of the unit.

## Uninterrupted Power Supply

The UPS shall fit within the server cabinet and shall be the same dimension as 1U/ 2U rack. Various capacities are available. Installation of the UPS is rack mounted. Full information of the installation is supplied with the UPS.

The UPS can be personalised to the application (response times etc) through a computer. This connection can be either RS232 or USB.

## Rack Mounted Temperature / Humidity Sensor

The temperature / humidity sensor is to be fitted on the front door of the rack so that the room condition can be correctly recognised by the OnRak. This then relates within the strategy of the microprocessor for dew point control. It should be positioned at the highest temperature point entering the rack.

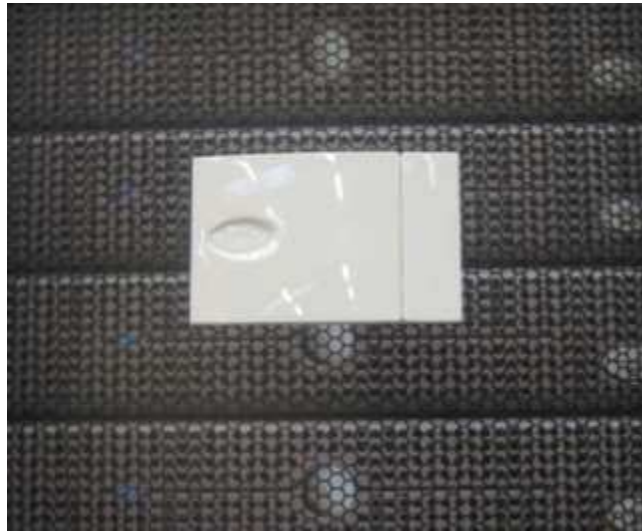

Temperature sensor mounted at the cold air inlet of a server rack.

The sensor is fitted with the supplied bracket.

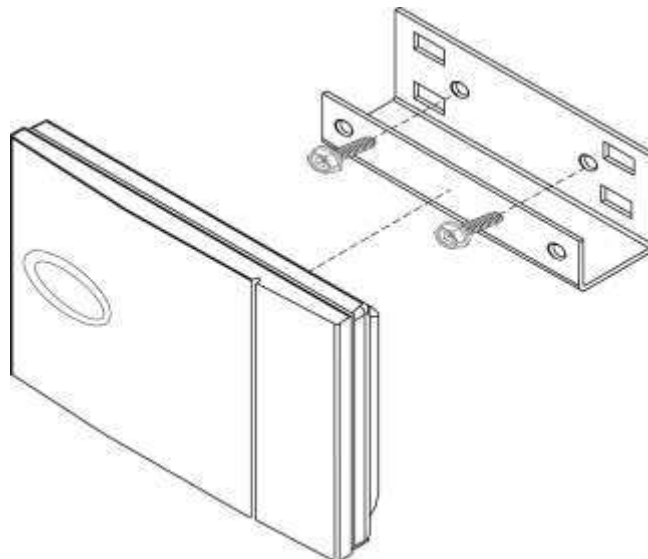

## Rack Pressure Management

The rack pressure management comes in two parts for onsite fitment.

### Part one (Factory Fitted)

A static pressure ring (Negative pressure) is fitted behind the coil guard. An airflow tube comes out from the controller and is then routed around the drip tray.

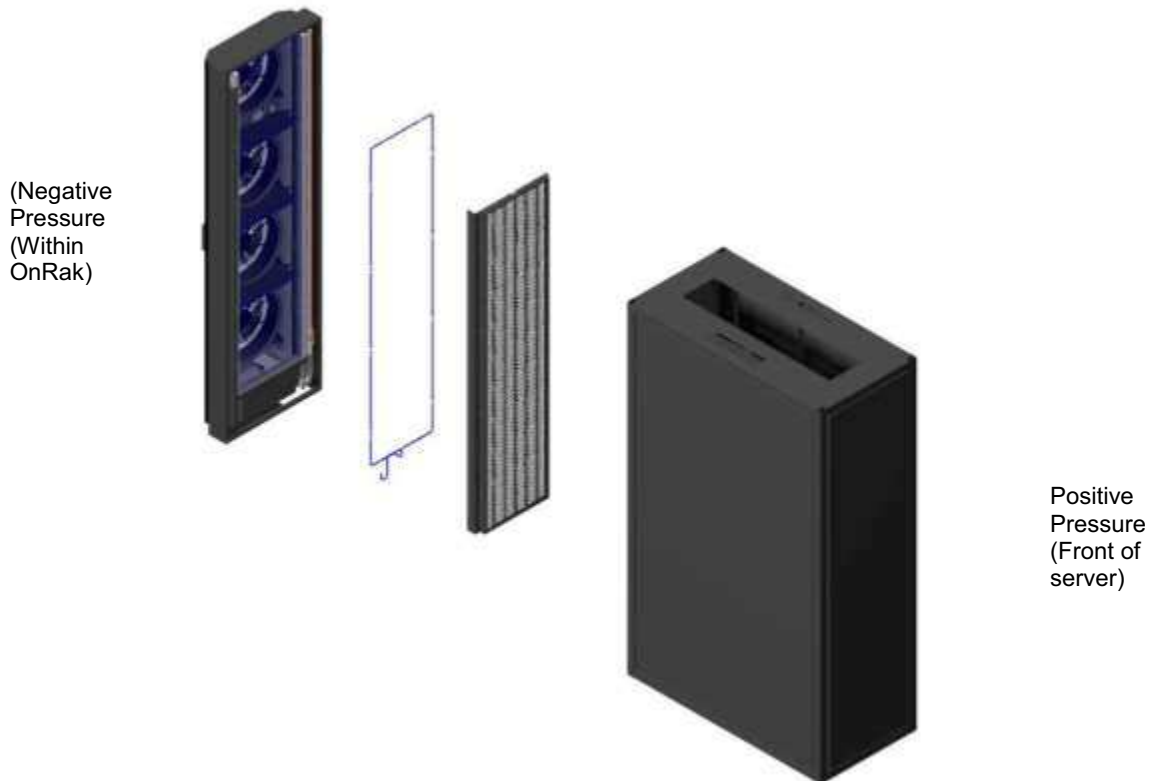

### Part two (Site Fitted)

A pressure tapping is then fixed to the inlet of the servers (+VE Positive Pressure) by the bracket supplied loose.



The pressure tapping is fitted with M3 screw to the bracket.

M5 Nut and bolt is then used to mount the bracket to the server door. The bracket is slotted to accommodate different mesh pitch.

The tubing leaves the OnRak door and must make its way diagonally towards the hinged side of the front of the rack (so that both doors can be opened without obstruction.)

Blue – ve (Negative pressure)

Red + ve (Positive pressure)

Care must be taken when routing the tubing around the server cabinet (Any kinks in the tubing will give faulty readings).

The server cabinet differential pressure is then controlled by the OnRak ensuring air is not forced over the IT equipment.

## Rack Sealing

The rack must be sealed so that air does not bypass the servers. The racks must not have any ventilation holes such as a perforated roof. Any space within the server racks that are redundant must be sealed with blanking panel (usually supplied in 1U and 2U).

The heat leaving the servers must be sensed by the OnRak to ensure correct operation.

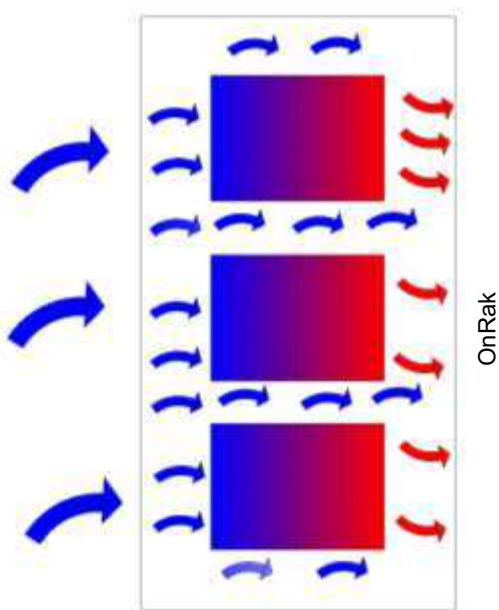

Figure 1 Wrong Cabinet not sealed

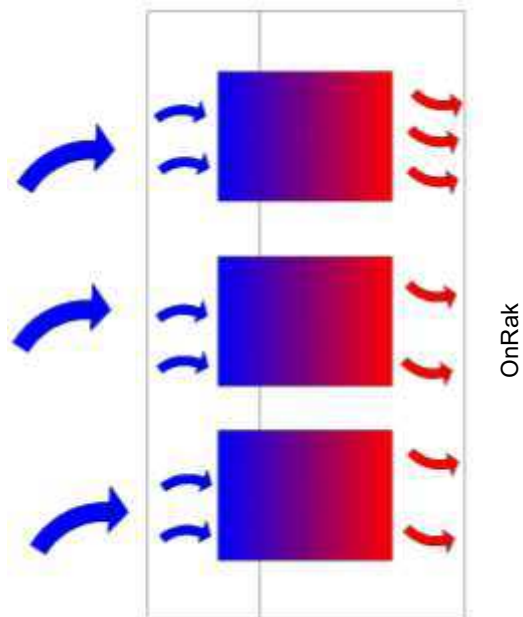

Figure 2 Right Cabinet sealed





## CAUTION



Any air bypass will reduce the efficiency of the unit and may cause overheating of the server racks due to the OnRak not detecting the cooling demand.



## Interconnecting Wiring

OnRak	L1	O	←		Mains incoming supply 230V/1PH/50Hz
	N1	O	←		
	PE	O	←		
	509	O	→		Flow solenoid valve
	500	O	→		Common
	509	O	→		Return solenoid valve
	500	O	→		Common
	824	O	→		Signal to chilled water valve
	500	O	→		Common
	502	O	→		24VAC
	827	O	←		Air on temperature
	828	O	←		Air on humidity
	502	O	←		24VAC
	500	O	←		Common
	SCR	O	←		Screened cable terminated at controller.
	561	O	→	Critical Alarm	Volt Free Common Alarm
	560	O	→		Volt Free Alarm N/O
	562	O	→		Volt Free Alarm N/C
	564	O	→	Non Critical Alarm	Volt Free Common Alarm
	563	O	→		Volt Free Alarm N/O
	RX-/Tx-	O	←	Use Awg20/22 twisted pair (with overall shield) cable, Belden ref. 8762 (Airedale ref: 6110316), or equivalent, for  network	 Network Connections (Inward connection)
	RX+/Tx+	O	←		
	GND	O	←		
	RX-/Tx-	O	→	Use Awg20/22 twisted pair (with overall shield) cable, Belden ref. 8762 (Airedale ref: 6110316), or equivalent, for  network	 Network Connections (Outward connection)
RX+/Tx+	O	→			
GND	O	→			

## Automatic Fan Disconnect

This type of connector removes the requirement for manual disconnection of the fan wiring, as removing the fan automatically and fully disconnects power from the fan.

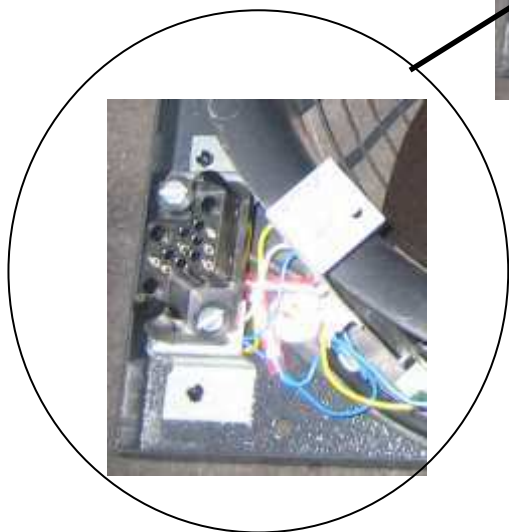
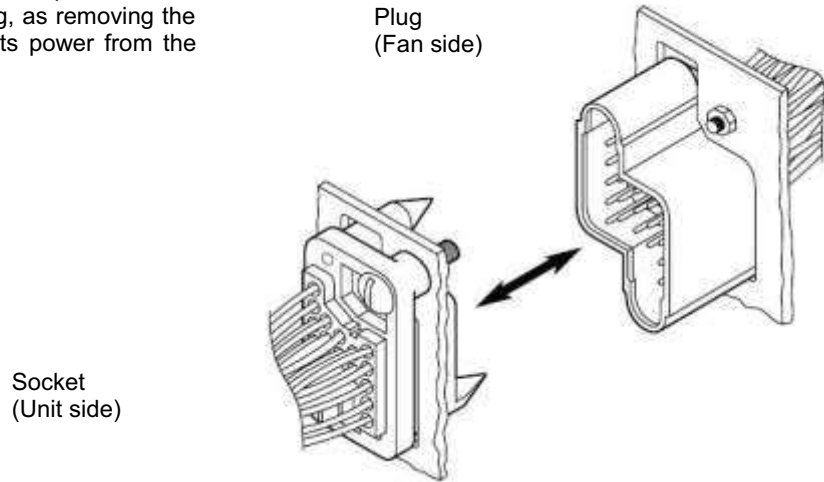

## Controls



### Addressing the Display Keypad

The address of the display keypad can be configured only after having connected the power supply, using the RJ11 connection cable.

To access configuration mode, press the  +  +  buttons together and hold them for at least 5 seconds; the screen shown below will be displayed, with the cursor flashing in the top left corner:

```
Display address  
setting:.....nn  
I/O Board address:xx
```

To change the address of the display keypad (display address setting), press the  button once: the cursor will move to the address field (nn).













Use the  or  buttons to select the desired value, and confirm by pressing  again. If the value selected is not the same as the one saved previously, the screen shown below will be displayed, and the new value will be saved to the permanent memory. If the field nn is set to 0, the terminal will communicate with the pCO board using “point-to-point” protocol (not pLAN) and the field “I/O Board address: xx” will not be displayed, as it has no meaning.

```
Display address  
changed
```





	1. ALARM	When more than one alarm is active the ALARM button will illuminate red. Pressing the ALARM button once will indicate information regarding any active alarms. Pressing the ALARM button twice will reset any active alarms.
	2. PRG	Pressing the PRG button will select the main navigation menu.
	3. ESC	Pressing the ESC button will return the user to the main display screen showing unit status.
	4. UP	Pressing the UP button can either: Scroll through the various display screens, providing the cursor is in the top left position. Increase the value of a set point adjustment.
	5. ENTER	Pressing the ENTER button will confirm any set point adjustments and move the cursor to the next available set point.
	6. DOWN	Pressing the DOWN button can either: Scroll through the various display screens, providing the cursor is in the top left position. Decrease the value of a set point adjustment.

## Extra Functions Buttons

 +  + 	UP + DOWN+ ENTER	Allow users to change display address.
 + 	ALARM + ENTER	Allows access to controller system information.
 + 	ALARM + UP	Allows access to change controller address (only when display address is zero)
 + 	ESC + ENTER	Allows the user to switch between the preinstalled languages
 + 	PRG + ENTER	Temporary displays the address of the controller.
 + 	ENTER + UP	Change unit on remote display keypad.

## Navigation

Initially, use the  button to access the main navigation menu, the cursor will appear in the top right hand corner with the first menu UNIT ON/OFF selected.

Use the  and  buttons to move to the desired menu. The selected menu will be shown in BLOCK CAPITALS.

Press  to enter the selected menu.





## Navigation Sub Menus

**There are eight sub menus available from the main navigation menu, these are listed below:**



1. Unit On/Off	Allows the user to switch on or switch off the unit.
2. Maintenance	Allows the user to view maintenance related parameters, such as hours run, sensor calibration and manual overrides.
3. Alarm Log	Allows the user to view the alarm log.
4. Input/Output	Allows the user to view the status of the controller inputs and outputs.
5. Clock	Allows the user to view the current time, date and day of the week. On/Off and temperature time zones can also be set.
6. Set point	Allows the user to adjust the return air temperature set point.
7. User	Allows the user to adjust user related parameters, such as high and low alarm limits and temperature bands.
8. Manufacturer	Allows the user to enter the manufacturer menu and adjust various manufacturer related parameters, such as unit configuration and timing settings.

## Enabling the Unit



To turn the unit on press the  key to enter the program menu. Using the  and  keys select the Unit On/Off option and press :



When  is pressed the above screen will be shown. To turn the unit on simply press the  key again and the screen will change:



Once the screen has changed to the above, press the  key which will return back to the main screen.

## Dew Point Control

The pCO controller within the OnRak unit can calculate the dew point within a room by monitoring the temperature and humidity of that room and then performing a calculation to provide a dew point value. The pCO controller uses a signal received from the temperature/humidity sensor which is wired into the controller.

The calculated value of dew point is then used to ensure that the supply water temperature to the OnRak is never less than two degrees below the dew point.

This ensures that no condensate or moisture build up can occur from the supply water being below the room's dew point.

To view the dew point information simply scroll down from the main page until the following screen is displayed:

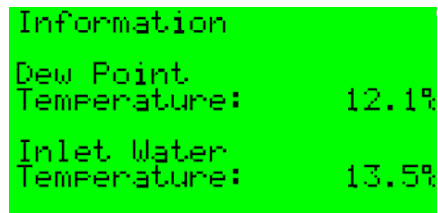

```
Information
Dew Point
Temperature:      12.1%
Inlet Water
Temperature:      13.5%
```

## Modulated Cooling

The OnRak can modulate its cooling performance to suit the heat being produced by the servers within the cabinet. It does this by modulating both the fan speed and the three way modulating valve to maintain the appropriate level of cooling.

The fans are designed to control the server discharge temperature to a user defined set point, defaulted to 40°C, whilst the three-way modulating valve is designed to match the air temperature off the fans with the air on temperature if the unit is configured to be temperature neutral, or to maintain the room temperature if the unit is configured to work as load neutral.

## Temperature Sensor Locations

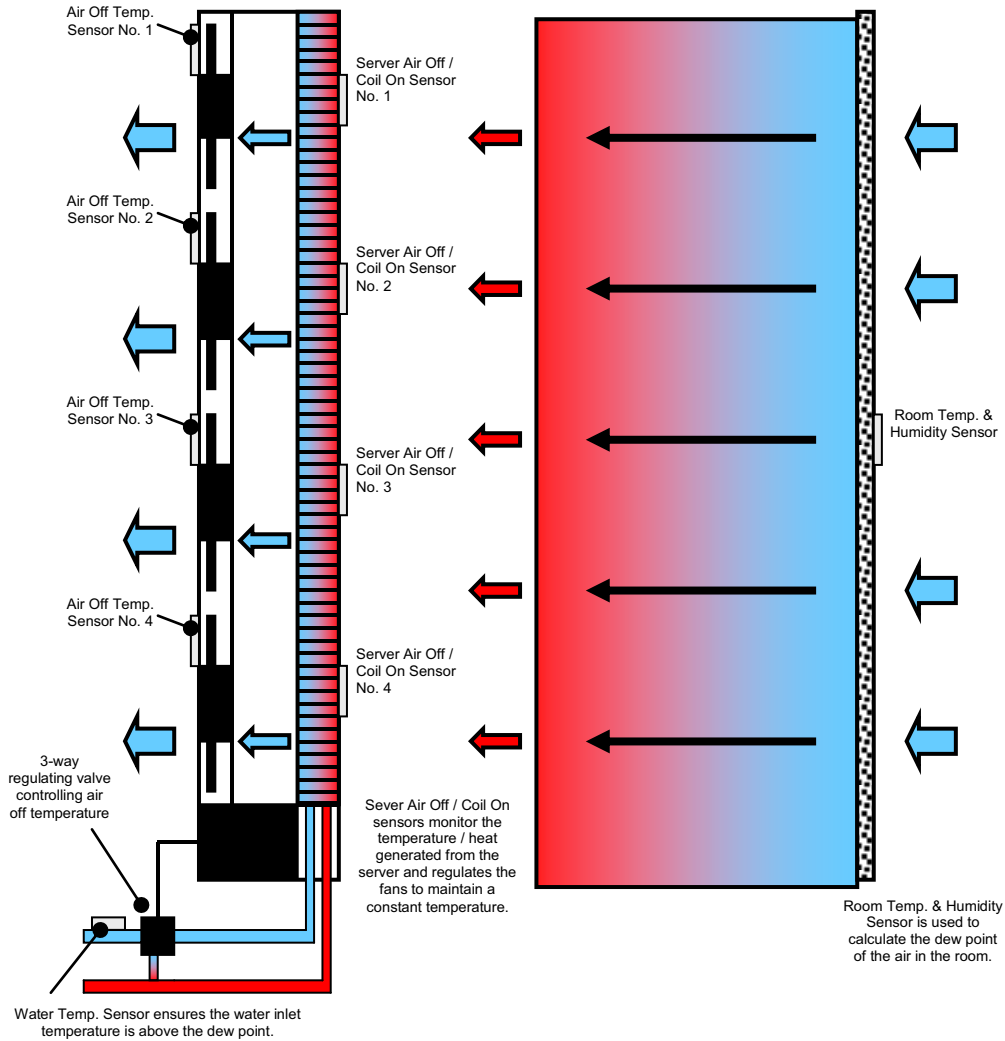



## Modes of Operation

### Temperature Neutral Mode

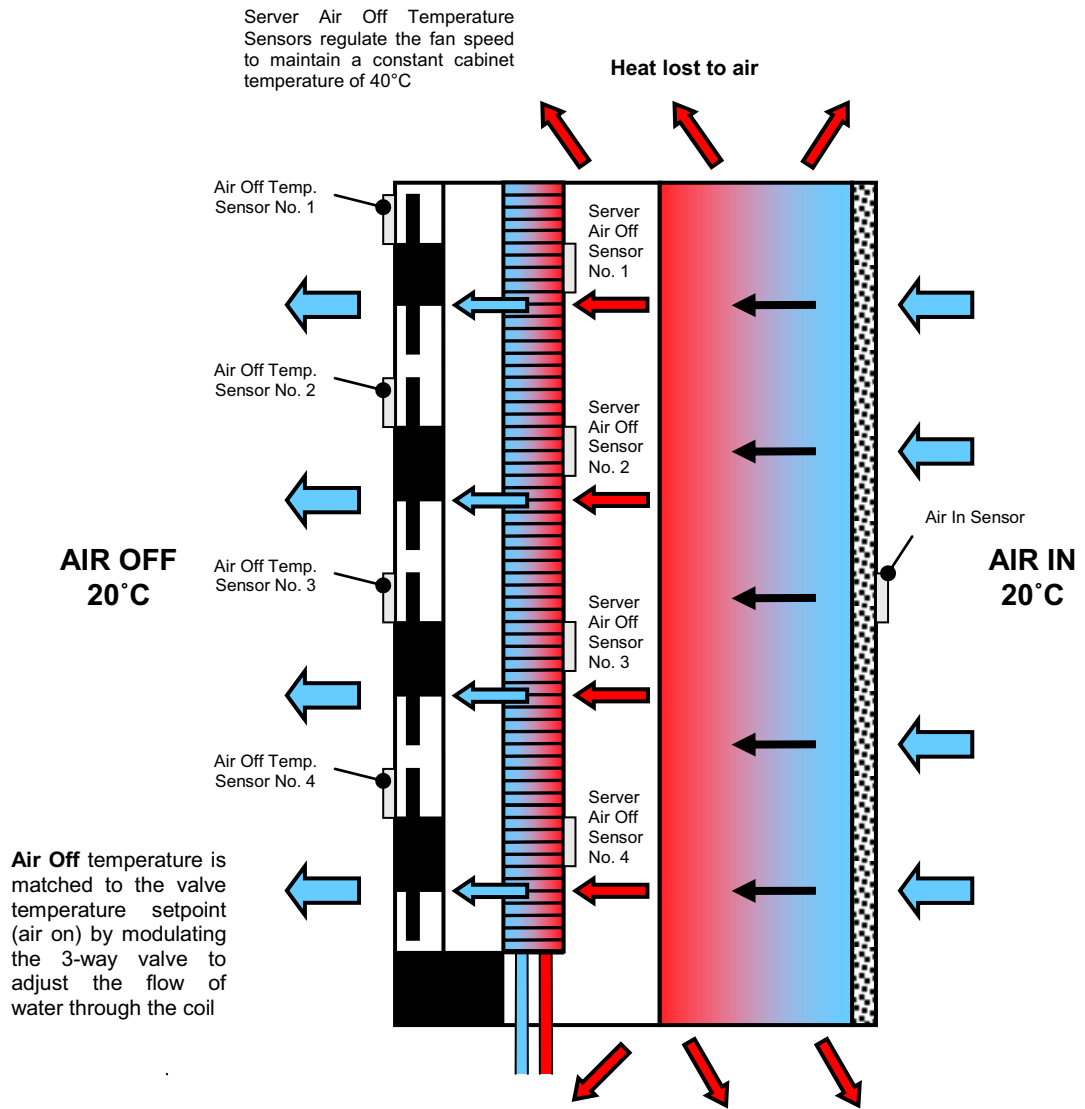

When operating in temperature neutral mode, the unit ensures the “Air Off” temperature is matched to the valve temperature setpoint irrespective of the surrounding room temperature. This mode of temperature control only considers the individual server unit load and not the impact of other equipment in the room on the surrounding environment.

## Load Neutral Mode

Server Air Off Temperature Sensors regulate the fan speed to maintain a constant cabinet temperature of 40°C

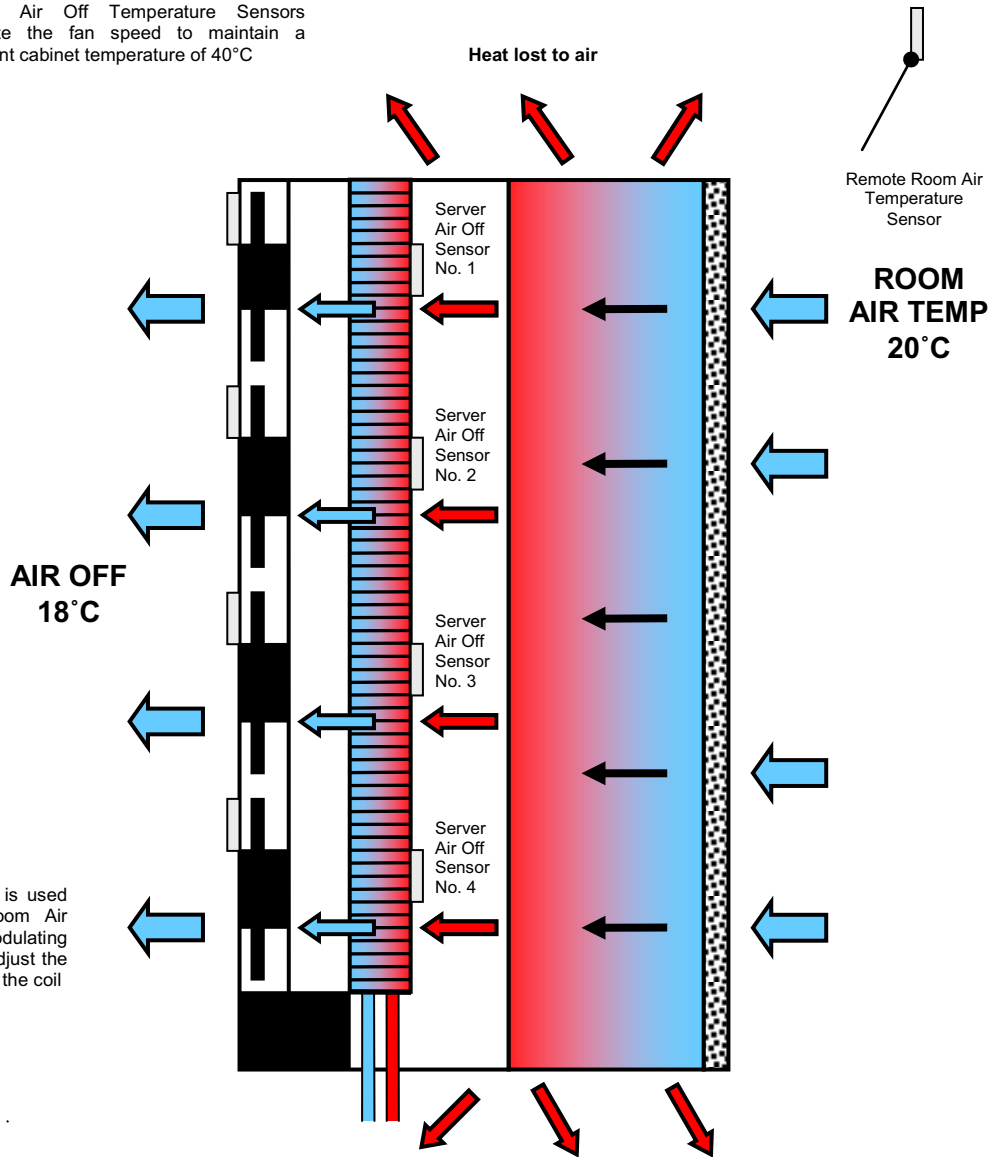

Air Off Temperature is used to maintain the Room Air Temperature by modulating the 3-way valve to adjust the flow of water through the coil

When operating in load neutral mode, the unit ensures the “Air On”/room temperature is modulated to maintain the valve temperature setpoint. In this condition the air temperature leaving the OnRak is less than the air temperature entering the server cabinet.

This mode of temperature control considers the impact of case heat radiation as well as the effect of other equipment on the surrounding environment. Using the OnRak in load neutral mode reduces the cooling capacity as the OnRak tries to maintain a room setpoint and operates in a similar manner to a CRAC unit.

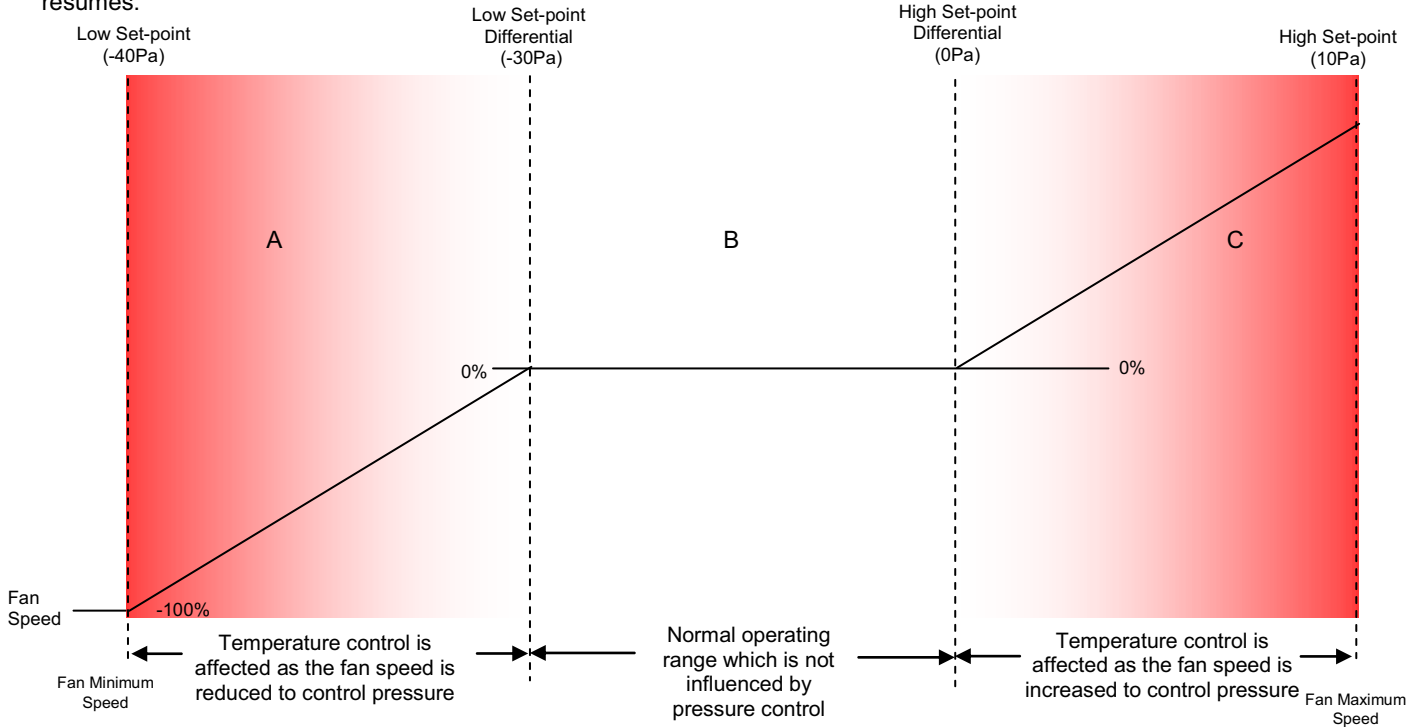

## Rack Pressure Management

The fans will operate to maintain the “air off” temperature as long as the pressure remains within the normal operating range. However, if the pressure within the server space changes beyond the high or low differential set-points, the fans prioritise pressure control to bring the server pressure back within limits, at which point normal temperature control resumes.



The diagram shows the normal operating area between the dotted lines (B) of the low and high set-point differentials. The red zones (A and C) indicate areas where the fans prioritise pressure control to bring it back within limits.

## Commissioning Procedure

<b>General</b>	To be read in conjunction with the commissioning sheets provided.
<b>CAUTION</b>	 <b>Please ensure all documents have been completed correctly and returned to Airedale technical support to validate warranty.</b>
<b>CAUTION</b>	 <b>All work MUST be carried out by Technically Trained and competent personnel.</b> The equipment contains live electrical and moving parts, Isolate prior to maintenance or repair work.
<b>General</b>	Visually inspect the unit for any mechanical damage that could have occurred during installation.
<b>Applying Mains Voltage</b>	Apply mains electrical supply to the unit.  Check the mains incoming voltage (230 Volts) carry this procedure out with all MCB's turned off. Turn on the MCB that supplies the transformer. Measure both the primary and secondary tapping. (230 Volts and 24 Volts respectively)  Turn on the remaining MCB.
<b>Turning Unit On</b>	Use the display to turn the unit on.  Using the display to enter maintenance mode. Within the parameters sub menu increase/decrease the fan output voltage. Check the current and fan speed with the unit running at full output. Record on commissioning sheet.
<b>3 Way Chilled Water Valve</b>	Check that the chilled water valve operates correctly and delivers water to the coil when the microprocessor is calling for cooling. Check that the valve goes into bypass with no demand or when in alarm.
<b>2 Way Chilled Water Valve</b>	Check that the chilled water valve operates correctly and delivers water to the coil when the microprocessor is calling for cooling. Check that the valve shuts off water with no demand or when in alarm.
<b>Solenoid Valve</b>	Ensure that the solenoids de-energise on alarm (making them close).
<b>Resetting Alarms</b>	Reset any alarms to ensure correct alarm monitoring.
<b>Door Open Alarm</b>	Ensure that the Door open alarm is activated when the door is opened, following delay.
<b>Leak Detection Alarm</b>	Check that the leak detection alarm operates. Apply a small controlled leak to verify that the alarm operates.
<b>Dual power Supply</b>	Check that the two power supplies are live. Ensure that the Dual power supply LED illuminate with correct power source.
<b>Uninterrupted Power Supply</b>	The UPS requires charging for a period of 8 hours before the internal battery can supply the rated backup time. The UPS charges the battery as soon as it is connected to the AC power supply.  Following its initial charge the UPS can be changed over to operate on battery power. During battery operation an audible alarm beep will sound every 10 seconds. Low battery warning the alarms beeps every 3 seconds. Automatic shutdown is imminent.  Upon return of AC input power the UPS will restart automatically (unless the restart function has been disabled via UPS personalisation).
<b>Static Transfer Switch</b>	The static transfer switch is to be commission as per the manufacturer's instructions.

---

## Commissioning Procedure

---

<b>Fan Removal Alarm</b>	Check alarm state when a fan goes offline.
<b>Differential Pressure</b>	<p>The differential pressure switch should cause the OnRak fans to increase / decrease when the server fans are active. One of the fans can be removed to allow the differential pressure to be recognised if the server load is low.</p> <p>If the server discharge temperature is high the differential pressure feature becomes second priority, ensuring that the cooling demand is satisfied.</p>
<b>Dew Point Control</b>	The dew point control feature will isolate the chilled water supply to the unit if the water temperature falls lower than the dew point temperature of the air. The OnRak water temperatures can be offset to produce this alarm through the maintenance parameter of the controller.
<b>Rack Support Wheel</b>	Ensure that the rack support wheel turns freely and supports the OnRak door when full of water.

## Maintenance

### Changing EC Fans

The fans are designed as plug and play “hot swap” enabling the fans to be changed without the need to disconnect the power from the entire unit. Removing the 4 security fixings enable the fan to be removed

The unit has automatic disconnect sockets to the fan motors. The remaining fans will increase speed to compensate for the fan being serviced (only in N+1 configuration)

### CAUTION



**The unit will remain live up to the fan disconnect socket.**

**Ensure that the fan stops rotating before placing hand near blades.**



### 2 or 3 Way Chilled Water Regulating Valve

The 2 or 3 way chilled water regulating valve actuator must be inspected to ensure a secure fixing to the valve body. The actuator is located onto the valve body by four pegs that are secured by a torque screw through the adjustment handle.

### Coil Guard Cleaning

The coil guard must be cleaned periodically. Carefully removing any debris. Be careful not to damage the temperature sensors.

### CAUTION



**When cleaning the coil guard, extreme care must be taken to ensure that the coil does not get damaged.**

## Operational Maintenance checks

### Owners Responsibility

To ensure that the unit can be maintained correctly the following requirements are required.

- Maintain a safe working environment around the unit, free from obstructions and debris.
- The unit shall follow the following maintenance regime as a minimum.



**The equipment contains live electrical and moving parts, ISOLATE prior to maintenance or repair work.**

**Ensure Lock off procedures is carried out accordingly.**

### Maintenance Schedule

Item	Task	Frequency		
		6 Mths	12 Mths	60 Mths
Unit Inspection				
<b>General Inspections</b>	Check for visible mechanical damage to unit.	•		
	Check for cleanliness	•		
	Visually inspect the unit for general wear and tear, treat metalwork.	•		
	<b>Rust should be inhibited, primed and touched up with matching paint.</b>			
	Check for excess vibration from other rotating equipment.	•		
<b>Coil Guard Cleaning</b>	Ensure that the coil guard is free from debris.	•		
<b>Electrical Inspection</b>	Check main power supply voltages	•		
	Check electrical terminals are tight.	•		
	Check that the control panel and fan assembly cables are securely fastened together.	•		
	Check amperages are as per design.	•		
<b>Controls alarm log</b>	Check alarm log for any spurious events.	•		
<b>Dual Power Supply</b>	Check operation of dual power supply.	•		
<b>Static Transfer Switch</b>	Check operation of static transfer switch. Referrer to manufacturer information.	•		
<b>Uninterrupted Power Supply</b>	Check operation of UPS. Ensure battery within UPS is holding charge.	•		

---

#### Service tools / Test Equipment

- Voltmeter
  - Screwdrivers/ Allen keys
- 

---

#### Safety Equipment

- Safety Glasses/ Goggles
-

## Troubleshooting

FAULT	POSSIBLE CAUSE	REMEDY/ACTION
<b>Unit will not start</b>	No power	Check power supply to the controller.
	Wired incorrectly	Check wire connections in accordance with wiring diagram on control panel.
	Loose wires	Check all wires, connections, terminals etc.
<b>Fan not operating - power on</b>	Power supply failure	Check power supply at circuit breaker.
	Wiring to motor	Check voltage at motor terminals.
	Motor / fan assembly jammed	Isolate unit and check free rotation of motor/fan assembly, if faulty – replace.
	Power disconnected to fans.	Carefully check status of power disconnect socket.
<b>Status indication LED faulty</b>	Wired incorrectly	Check that the wiring to the LED has the correct polarity.  Check that the terminations are correct.
<b>Display faulty</b>	Does not illuminate	Faulty cable- Replace cable.
	Wrong display address	Faulty display – Replace display. Change address of display (see controls section)
<b>No Cooling</b>	Low water flow through coil	Ensure any chilled water valves are open and not in bypass.
		Ensure that any solenoid valves are open when there is a demand for cooling.
		Water temperature sensor faulty. The sensor has failed causing the valves on the unit to close.
<b>UPS</b>	The UPS system does not operate correctly	Please refer to the UPS documentation / fault codes. Various solutions are available from changing battery modules to module restart.
<b>Water Leak Detection</b>	Damaged flexible hose	Ensure that the flexible hose is not rubbing on the coil or sheet metal in the vicinity of the door.
	Condensation has formed on coil	Check operating conditions ensuring that the unit operates with its dew point control feature.











**Head Office:**

**Airedale International Air Conditioning Ltd  
Leeds Road  
Rawdon  
Leeds LS19 6JY  
United Kingdom**

**Tel: +44 (0) 113 239 1000  
Fax: +44 (0) 113 250 7219**

**e-mail: [enquiries@airedale.com](mailto:enquiries@airedale.com)  
website: [www.airedale.com](http://www.airedale.com)**



**SYSTEMY HVAC Sp. z o.o.**  
ul. Rydygiera 8, 01-793 Warszawa  
tel.: +48 22 101 74 00  
fax: +48 22 101 74 01  
e-mail: [biuro@systemy-hvac.pl](mailto:biuro@systemy-hvac.pl)  
[www.systemy-hvac.pl](http://www.systemy-hvac.pl)

<b>PART NO:</b>	<b>ISSUE</b>
<b>(TM E)</b>	<b>12/2009</b>
<b>V1.1.0</b>	<b>11/2010</b>
	<b>12/2010</b>
<b>V1.3.0</b>	<b>02/2011</b>
<b>V1.4.0</b>	<b>05/2011</b>
<b>V1.5.0</b>	<b>09/2012</b>
<b>V1.6.0</b>	<b>02_2013</b>
<b>V1.7.0</b>	<b>01_2014</b>